

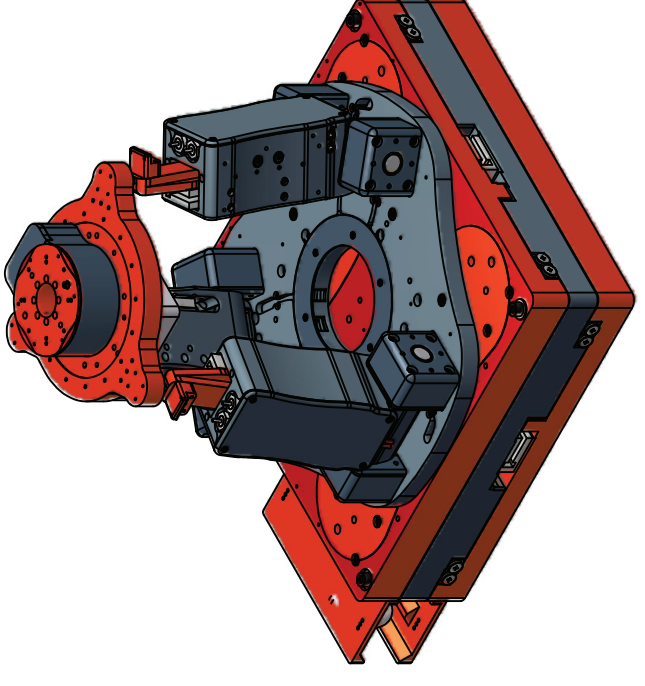

ALIO STAGE AND MOTOR SPECIFICATIONS



ALIO INDUSTRIES PROPRIETARY INFORMATION
(Tel) 303.339.7500 - SALES@ALIOINDUSTRIES.COM - WWW.ALIOINDUSTRIES.COM



TITLE
AI-6D-(XY TRAVEL)XY-(Z TRAVEL)Z-(R DIAMETER)R-(OPTION)

SIZE B DWG NO 0010-08007 REV 002

SCALE 1 OF 1 SHEET 1

4 3 2 1

MODEL	UNITS	AI-6D-100XY-6Z-56R	AI-6D-100XY-6Z-56R-CM	AI-6D-100XY-24Z-56R	AI-6D-100XY-24Z-56R-CM-MS	AI-6D-150XY-40Z-56R	AI-6D-200XY-40Z-104R	AI-6D-250XY-55Z-104R	AI-6D-300XY-106Z-104R
OPTION	--	--	--	--	"CM"=LOW FORCE XY "MS"=MAGNETIC SPRING	--	--	--	--
XY TRAVEL	mm	100	100.0	100	100	150	200	250	300
Z TRAVEL	mm	6.0	6.0	24	24	40	40	55	106
PITCH AND ROLL RANGE [9]	deg	+/-3	+/-3	+/-12	+/-12	+/-16	+/-12	+/-16	+/-18
YAW TRAVEL	deg				360 degrees continuous				
MAX LINEAR VELOCITY [10]	m/s	0.4	0.05	0.5	0.5	0.5	0.5	0.5	0.5
MAX ANGULAR VELOCITY (PITCH & ROLL) [10]	deg/s	90	90	90	90	90	90	90	90
MAX ANGULAR VELOCITY (YAW) [10]	deg/s	720	720	720	720	720	720	720	720
ASSEMBLY MASS	kg	17.2	10.0	18.4	13.1	30	46	72	105
X MOVING MASS	kg	14.4	8.6	15.6	11.3	26.7	35.0	57	84
Y MOVING MASS	kg	7.8	6.3	9.0	6.3	19.0	25.6	35	52
Z MOVING MASS	kg	1.40	1.40	2.3	2.6	3.9	5.7	6.6	10.5
YAW MOVING MASS	kg	0.25	0.25	0.25	0.25	0.25	0.9	0.9	0.9
YAW MASS MOMENT OF INERTIA	kg mm ²	85	85	85	85	85	900	900	900
MAX PAYLOAD [11]	kg	2.0	2.0	2.5	2.5	2.5	5	5	7
MAX CENTER OF GRAVITY HEIGHT [11,12]	mm	40	40	40	40	40	50	50	50
COUNTERBALANCE PRESSURE [13]	psi	30	30	--	--	40	50	50	70
LINEAR RESOLUTION	nm	-5	-5	-5	-5	-5	-5	-5	-5
PITCH AND ROLL RESOLUTION	arc-sec	-0.03	-0.03	-0.02	-0.02	-0.02	-0.01	-0.01	-0.01
YAW RESOLUTION	arc-sec	0.04	0.04	0.04	0.04	0.04	0.02	0.02	0.02
YAW ROTARY STAGE	Model	AI-TM-56R	AI-TM-56R	AI-TM-56R	AI-TM-56R	AI-TM-56R	AI-TM-104R	AI-TM-104R	AI-TM-104R
XY LINEAR STAGE	Model	AI-LM-10000-XY	AI-LM-10000-XY	AI-LM-10000-XY	AI-LM-10000-XY	AI-LM-15000-XY	AI-LM-20000-XY	AI-LM-25000-XY	AI-LM-30000-XY

TRIPOD MOTOR INFORMATION		LINEAR BRUSHLESS	
MOTOR TYPE			
MOTOR MODEL	--	P16-0.5	P16-1
MAGNETIC PITCH (N-N)	mm	30.48	30.48
MAX VOLTAGE (LINE TO LINE) [1]	V	500	500
ELECTRICAL TIME CONSTANT	msec	0.14	0.20
MAX MOTOR TEMP	°C	130	130
MOTOR CONNECTION	--	DELTA CONNECTED	DELTA CONNECTED
FORCE CONSTANT	N/Apk	3.5	7.2
PHASE RESISTANCE (@25°C) [2,3]	Ohm	2.9	2.9
PHASE RESISTANCE (@130°C) [2,3]	Ohm	4.2	4.2
INDUCTANCE	mH	0.6	0.6
CONTINUOUS FORCE [4]	N	10	15
CONTINUOUS CURRENT [4]	Apk	2.8	2.1
PEAK FORCE [5]	N	21	74
PEAK CURRENT [5]	Apk	6.0	10.3
BACKEMF CONSTANT	V/m/s	3.5	7.2

XY MOTOR INFORMATION		FRAMELESS TORQUE MOTOR	
MOTOR TYPE			
MOTOR MODEL	--	044050-EY	044050-EY
MAGNETIC PITCH (N-N)	deg	120	120
MAX VOLTAGE (LINE TO LINE) [1]	VDC	340	340
MAX MOTOR TEMP	°C	155	155
TORQUE CONSTANT	Nm/Arms	0.091	0.091
PHASE RESISTANCE (@25°C) [14]	Ohm	4.5	4.5
INDUCTANCE	mH	3.2	3.2
CONTINUOUS TORQUE [15]	Nm	0.21	0.21
CONTINUOUS CURRENT [15]	Arms	2.3	2.3
PEAK TORQUE	Nm	0.66	0.66
PEAK CURRENT	Arms	7.3	7.3
BACKEMF CONSTANT	V/m/s/krpt	5.5	5.5

XY MOTOR INFORMATION		LINEAR BRUSHLESS	
MOTOR TYPE			
MOTOR MODEL	--	P12-2	P12-2
MAGNETIC PITCH (N-N)	mm	30.48	30.48
MAX VOLTAGE (LINE TO LINE) [1]	V	500	500
ELECTRICAL TIME CONSTANT	msec	0.19	0.19
MAX MOTOR TEMP	°C	130	130
MOTOR CONNECTION	--	DELTA CONNECTED	DELTA CONNECTED
FORCE CONSTANT	N/Apk	16.3	16.3
PHASE RESISTANCE (@25°C) [2,3]	Ohm	11.6	11.6
PHASE RESISTANCE (@130°C) [2,3]	Ohm	16.4	16.4
INDUCTANCE	mH	2.1	2.1
CONTINUOUS FORCE [4]	N	47	47
CONTINUOUS CURRENT [4]	Apk	2.9	2.9
PEAK FORCE [5]	N	151	151
PEAK CURRENT [5]	Apk	9.2	9.2
BACKEMF CONSTANT	V/m/s	16.3	16.3

Notes:

1. Back EMF plus IR drop must not exceed maximum line to line voltage.
2. Resistance values do not include cable resistance. For P16 motors cable resistance adds 0.146 ohm/m for Delta connection and 0.44 ohm/m for Wye Connection.
3. Resistance values do not include cable resistance. For C12 motors cable resistance adds 0.251 ohm/m for Delta connection.
4. Continuous operating limits are based on continuous operation at maximum temperature with aluminum heat sink (300mm x 12.5mm x motor length).
5. Maximum on time at peak operating limits is 10 seconds.
6. Motor Connection type is internal to motor. All stages provided with default Delta connection unless otherwise specified.
7. All electrical specifications may vary by 12% from listed values.
8. Additional motor options are available for each stage for optimized performance as necessary per customer requirements.
9. Angular travel is measured when the Z axis is at mid-stroke and the other angle is zero degrees. Deviation from this specified off axis position reduces angular travel.
10. Maximum velocity specified is for motor in unloaded state. Stage velocity limitations vary greatly depending on stage load and motion profile.
11. Higher payload options available upon special request.
12. Contact ALIO technical sales for questions concerning high or offset centers of gravity.
13. Pneumatic counterbalance supply pressure listed is the estimated pressure required at the max payload.
14. Resistance values do not include cable resistance. Cable resistance adds 0.3 ohm/m.
15. Continuous operating limits are based on continuous operation at maximum temperature with aluminum heat sink (300mm x 300mm x 25mm).

DRAWN NBROWN
CHECKED

5/12/2012

Tolerances: Surface Roughness:
x.x ± .05 in [1.3 mm]
x.xx ± .01 in [0.25 mm]
x.xxx ± .005 in [0.13 mm]
Angles ± 0.5°
MATERIAL

FINISH SEE NOTES

4 3 2 1

B

A

B

A