

ECS3060

nanoprecise open loop stepper positioner for linear, horizontal motion

Technical Specifications

Technology

travel mechanism inertial piezo drive

Size and Dimensions

footprint; height 30 x 60; 9.5 mm
maximum size 30 x 96.6; 9.5 mm
weight (aluminum/stainless steel) 59/110 g

Coarse Positioning Mode

input voltage range 0 .. 60 V
typical actuator capacitance 1.15 μ F @ 300K
travel range (step mode) 35 mm
typical minimum step size 0.05 μ m
maximum drive velocity (@ 45 V) 4.5 mm/s

Fine Positioning Mode

input voltage range 0 .. 60 V
fine positioning range 0 .. 1.6 μ m
fine positioning resolution sub-nm

Materials

positioner body (/RT) aluminum
positioner body (/HV, /UHV) stainless steel
actuator PZT ceramics
connecting wires insulated twisted pair, copper
bearings stainless steel

Load (@ ambient conditions)

mounting orientation: axis horizontal

maximum load 180 N (18 kg)
maximum dynamic force along the axis 1 N
/HL high load option (maximum dynamic force) 5 N

Mounting

from the top 4 through holes dia 2.2 mm, cntrbr. f. M2
from the bottom 4 threads for M2.5 x 2 mm
load on top 12 threads M2 x 2.3 mm
load at the front L-bracket

Article Numbers

/RT version aluminum 1005655
/RT version stainless steel 1005668
/HV version stainless steel 1005680
/UHV version stainless steel 1005692
Article Numbers /HL Option 0

Compatibility with Electronics

ECC100 piezo positioning controller all versions

Working Conditions

mounting orientation arbitrary
temperature range (/RT, /HV, /UHV) 0 .. 100 °C
max. bake out temperature (/UHV) 150 °C
minimum pressure (/RT) 1E-4 mbar
minimum pressure (/HV) 1E-8 mbar
minimum pressure (/UHV) 5E-11 mbar

Accuracy of Movement

repeatability of step sizes typically 5 % over full range
forward / backward step asymmetry 10%
yaw angle (over 10 mm travel) < 0.1 mrad
pitch angle (over 10 mm travel) < 0.1 mrad
roll angle (over 10 mm travel) < 0.1 mrad

Position Encoder

encoder options -

Connectors and Feedthroughs

	/RT Versions	all /HV, /UHV Versions
connector type	14-pole connector	15-pin D-Sub connector
	50 cm cable with connector	50 cm cable with connector
electrical feedthrough solution	---	VFT/HV, VFT/UHV

Technical Drawings

top view

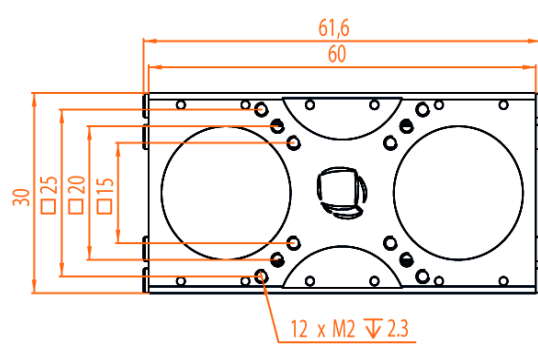

bottom view

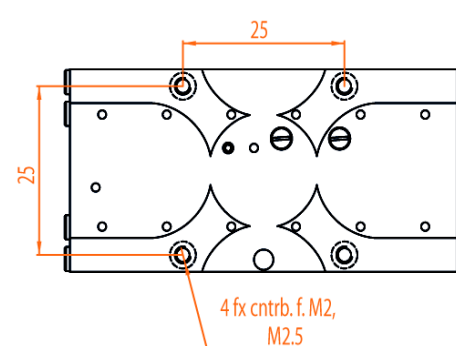

3D view



inner position

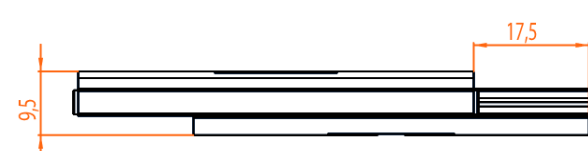

outer position

