



**Step Direction Controller
Adapter Board with Housing
SDC-2C-DS
Data Sheet**

Table of Contents

| | | |
|-----|--|---|
| 1 | Manufacturer Declarations..... | 3 |
| 1.1 | Warnings and Safety Instructions..... | 3 |
| 2 | Safety Precautions..... | 4 |
| 3 | Adapter Board for 2x SDC-1DS Boards..... | 5 |
| 3.1 | Pin Assignment..... | 5 |
| 3.2 | Multipoint Connector (back side)..... | 9 |

1 Manufacturer Declarations

1.1 Warnings and Safety Instructions

Please note the following warnings and safety instructions carefully when using the product.

1.1.1 Danger - Hazardous Voltage

The SDC controller described in this manual is capable of generating high output currents at high voltages. They may cause serious or even lethal injury if used improperly.

- Do never touch any part that might be connected to an output with a high voltage.
- Do not connect products from other manufacturers to the output connectors.

Output connectors with dangerous signals are labelled with the following symbol:



Please note that the Sensor Modules connected to these connectors have pins with a high voltage, too.

1.1.2 Caution - Installation Instructions

The SDC controller controller must be installed horizontally with 3cm air circulation area behind the ventilator. Insufficient air flow can cause overheating, which can result in a limited functionality of the controller.

2 Safety Precautions

To avoid damage of the SDC controller or the positioners used, please note the following precautions while using the products.

- It can't be guaranteed, that the SDC controller is able to drive stepping positioners from other manufactures without damage. Also do not try to drive the positioners with other controllers than those from SmarAct. Using other controllers may cause serious damage.
- Always make sure that the SDC controller and especially the ventilator is not blocked up by other devices.
- Please avoid dusty or high humidity working environments.

3 Overview

The SDC adapter board can host two SDC-1DS OEM boards. The board itself can be placed in a table-top housing that allows a comfortable operation of the controller.

The figure below shows the connectors at the SDC controller housing.

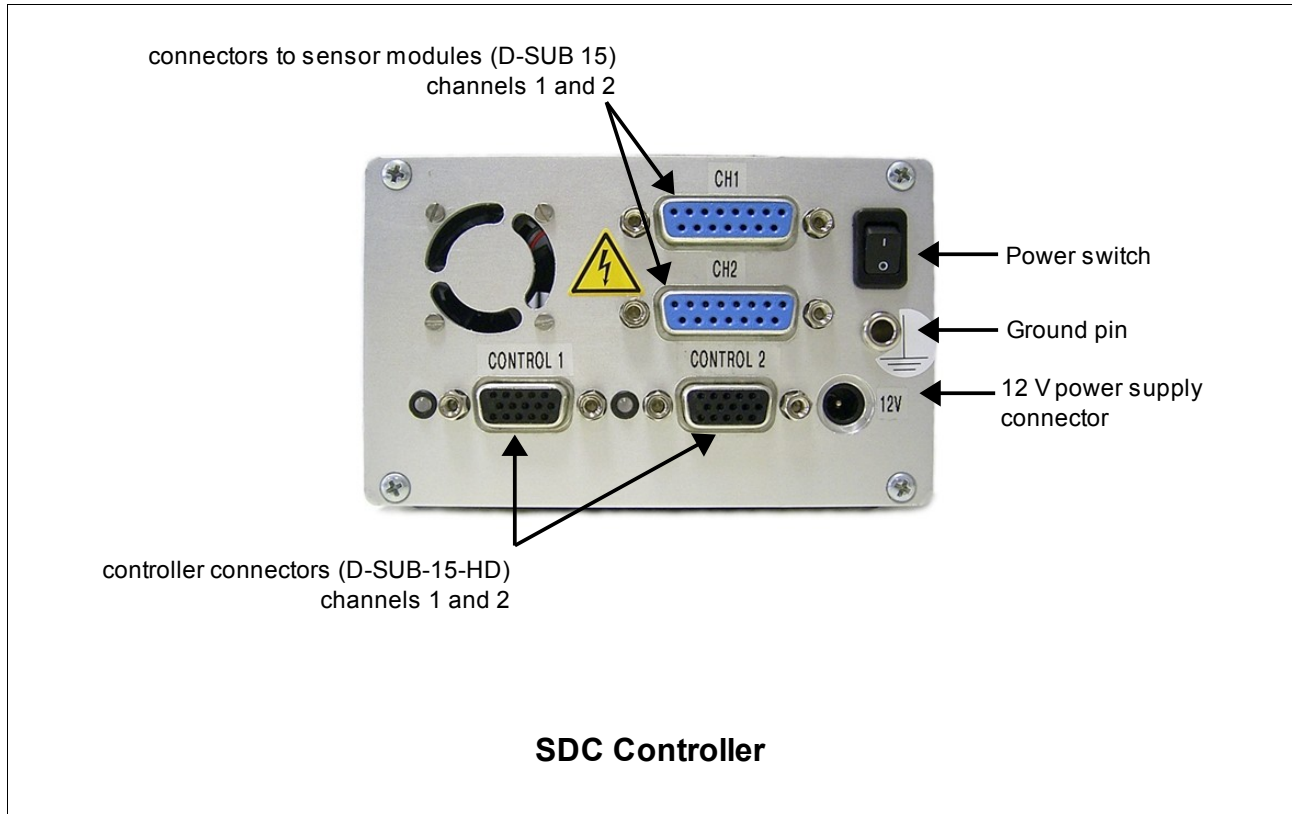

4.1.1 Control Connector (D-SUB-15-HD, female)

The pin assignment of the female D-SUB-15-HD connector for the digital control and the digital feedback is as follows:

| Pin | Signal | Description |
|------------|---------------|--|
| 1 | GND | Ground |
| 2 | ON/OFF | Switch's off the high voltage and / or control loop, depending on the DIP switch setting (see below) |
| 3 | ENABLE | Enabled the CLK input |
| 4 | CLK (Step) | Changes the target position |
| 5 | DIR | Specifies the direction of the position change |
| 6 | d.n.c. | DO NOT CONNECT |
| 7 | d.n.c. | DO NOT CONNECT |
| 8 | GND | Ground |
| 9 | d.n.c. | DO NOT CONNECT |
| 10 | d.n.c. | DO NOT CONNECT |
| 11 | LIM+ | Displays positive end stop (External pull up required) |
| 12 | LIM- | Displays negative end stop (External pull up required) |
| 13 | HOME | Displays reference mark (External pull up required) |
| 14 | PC-TXD | Communication with PC (controller to PC) |
| 15 | PC-RXD | Communication with PC (PC to controller) |

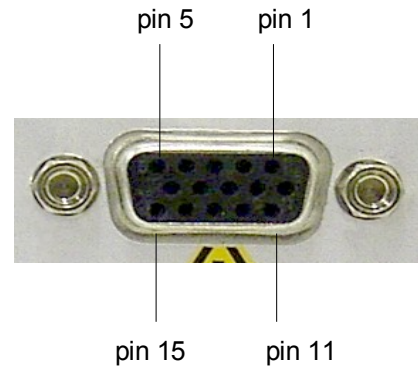

4.1.2 Connector to Sensor Module (DSUB 15, female)

There are two different models of the sensor module.

- In the standard version the signals for the actuator (HV-OUT and HV-GND) are led through the sensor module.
- In a sensor-only version the signals for the actuator (HV-OUT and HV-GND) are led separately to the positioners.

The pin assignment of the female D-SUB-15 connector to a standard sensor module is as follows:

| Pin | Signal | Description |
|------------|---------------|---------------------------------------|
| 1 | HV-OUT | Positioner driving signal |
| 2 | d.n.c. | DO NOT CONNECT |
| 3 | d.n.c. | DO NOT CONNECT |
| 4 | SM-GND | Ground for sensor module |
| 5 | SM-D- | RS-485 D- signal for sensor module |
| 6 | d.n.c. | DO NOT CONNECT |
| 7 | d.n.c. | DO NOT CONNECT |
| 8 | HV-GND | Ground for positioner driving signal |
| 9 | d.n.c. | DO NOT CONNECT |
| 10 | d.n.c. | DO NOT CONNECT |
| 11 | d.n.c. | DO NOT CONNECT |
| 12 | SM-D+ | RS-485 D+ signal for sensor module |
| 13 | d.n.c. | DO NOT CONNECT |
| 14 | SM-5V | Power supply for sensor module, 5V DC |
| 15 | SM-5V | Power supply for sensor module, 5V DC |

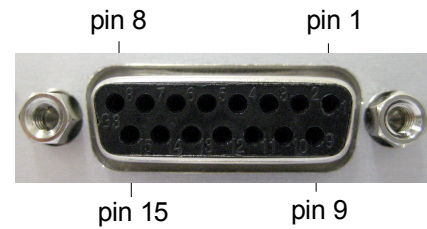

The pin assignment of the female D-SUB-15 connector to a sensor-only sensor module and a separate actuator is as follows:

| Pin | Signal | Description |
|------------|---------------|---------------------------------------|
| 1 | HV-OUT_C1 | Positioner driving signal |
| 2 | HV-OUT_C2 | Positioner driving signal |
| 3 | d.n.c. | DO NOT CONNECT |
| 4 | SM-GND | Ground for sensor module |
| 5 | SM-D_C1 | RS-485 D- signal for sensor module |
| 6 | SM-D_C2 | RS-485 D- signal for sensor module |
| 7 | SM-5V_C2 | Power supply for sensor module, 5V DC |
| 8 | SM-5V_C1 | Power supply for sensor module, 5V DC |
| 9 | HV-GND | Ground for positioner driving signal |
| 10 | d.n.c. | DO NOT CONNECT |
| 11 | d.n.c. | DO NOT CONNECT |
| 12 | SM-D+_C1 | RS-485 D+ signal for sensor module |
| 13 | SM-D+_C2 | RS-485 D+ signal for sensor module |
| 14 | SM-5V_C2 | Power supply for sensor module, 5V DC |
| 15 | SM-5V_C1 | Power supply for sensor module, 5V DC |

4.2 Multipoint Connector (back side)

The pin assignment of the 96 pin connector at the rear side of the adapter board is as follows:

| Pin | Signal | Description |
|------------|---------------|--|
| A1 | EXT_GND | Supply voltage Ground, separated by filter from GND |
| A2 | d.n.c. | DO NOT CONNECT |
| A3 | d.n.c. | DO NOT CONNECT |
| A4 | d.n.c. | DO NOT CONNECT |
| A5 | EXT_GND | Supply voltage Ground, separated by filter from GND |
| A6 | EXT_V_INPUT | Supply voltage, separated by filter |
| A7 | HOME_C1 | Indicates reference mark |
| A8 | LIM-_C1 | Indicates negative end stop |
| A9 | LIM+_C1 | Indicates positive end stop |
| A10 | GND | Signal Ground |
| A11 | SM-D+_C1 | RS-485 D+ signal for sensor module |
| A12 | SM-D-_C1 | RS-485 D- signal for sensor module |
| A13 | SM-5V_C1 | Power supply for sensor module, 5V DC |
| A14 | GND | Signal Ground |
| A15 | ON/OFF_C1 | Switches off the high voltage and / or control loop, depending on the DIP switch setting |
| A16 | CLK (Step)_C1 | Changes the target position |
| A17 | DIR_C1 | Specifies the direction of the position change |
| A18 | ENABLE_C1 | Enables CLK input |
| A19 | GND | Signal Ground |
| A20 | PC TXD_C1 | Communication with PC (controller to PC) |
| A21 | PC RXD_C1 | Communication with PC (PC to controller) |
| A22 | GND | Signal Ground |
| A23 | d.n.c. | DO NOT CONNECT |
| A24 | d.n.c. | DO NOT CONNECT |
| A25 | GND | Signal Ground |
| A26 | d.n.c. | DO NOT CONNECT |
| A27 | d.n.c. | DO NOT CONNECT |
| A28 | GND | Signal Ground |
| A29 | EXT_V_INPUT | Supply voltage, separated by filter |
| A30 | EXT_V_INPUT | Supply voltage, separated by filter |
| A31 | EXT_GND | Supply voltage Ground, separated by filter from GND |
| A32 | EXT_GND | Supply voltage Ground, separated by filter from GND |

| Pin | Signal | Description |
|-----------------|---------------|--|
| B1-B5, B31, B32 | EXT_GND | Supply voltage Ground, separated by filter from GND |
| B6 - B30 | d.n.c. | DO NOT CONNECT |
| C1 | HV+_C1 | Positioner driving signal |
| C2 | HV+_C2 | Positioner driving signal |
| C3 | d.n.c. | DO NOT CONNECT |
| C4 | EXT_GND | Supply voltage Ground, separated by filter from GND |
| C5 | GND | Signal Ground |
| C6 | EXT_V_INPUT | Supply voltage, separated by filter |
| C7 | Home_C2 | Indicates the reference mark |
| C8 | LIM-_C2 | Indicates negative end stop |
| C9 | LIM+_C2 | Indicates positive end stop |
| C10 | GND | Signal Ground |
| C11 | SM-D+_C2 | RS-485 D+ signal for sensor module |
| C12 | SM-D-_C2 | RS-485 D- signal for sensor module |
| C13 | SM-5V_C2 | Power supply for sensor module, 5V DC |
| C14 | GND | Signal Ground |
| C15 | ON/OFF_C2 | Switches off the high voltage and / or control loop, depending on the DIP switch setting |
| C16 | CLK (Step)_C2 | Changes the target position |
| C17 | DIR_C2 | Specifies the direction of the position change |
| C18 | ENABLE_C2 | Enables CLK input |
| C19 | GND | Signal Ground |
| C20 | PC TXD_C2 | Communication with PC (controller to PC) |
| C21 | PC RXD_C2 | Communication with PC (PC to controller) |
| C22 | GND | Signal Ground |
| C23 | d.n.c. | DO NOT CONNECT |
| C24 | d.n.c. | DO NOT CONNECT |
| C25 | GND | Signal Ground |
| C26 | d.n.c. | DO NOT CONNECT |
| C27 | d.n.c. | DO NOT CONNECT |
| C28 | GND | Signal Ground |
| C29 | EXT_V_INPUT | Supply voltage, separated by filter |
| C30 | EXT_V_INPUT | Supply voltage, separated by filter |
| C31 | EXT_GND | Supply voltage Ground, separated by filter from GND |
| C32 | EXT_GND | Supply voltage Ground, separated by filter from GND |