

## CS Series

*High-Speed 3D Compact Sensors with Ultra HD Resolution*

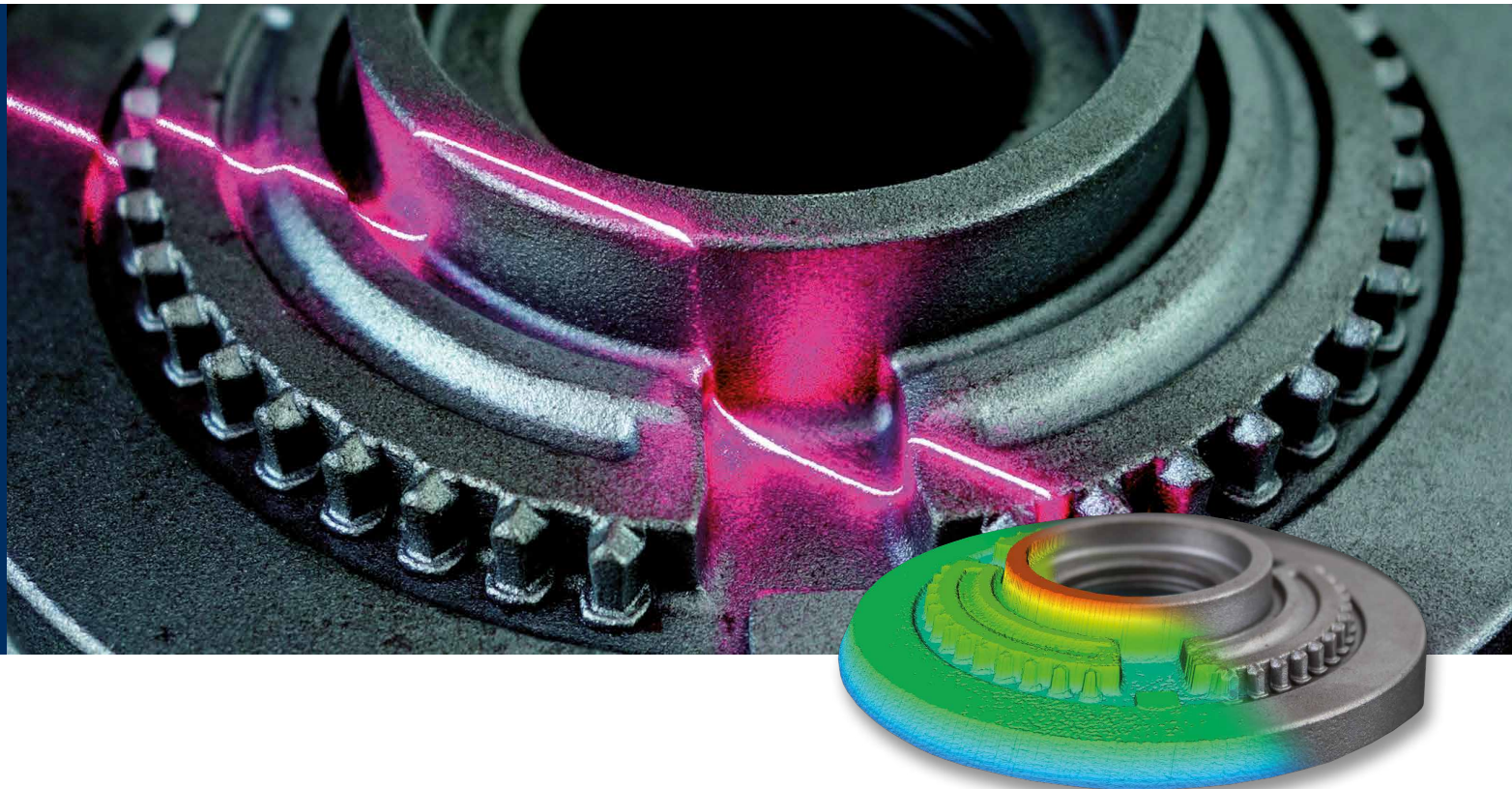

- ✓ 3D compact sensors based on laser triangulation
- ✓ Up to 4,096 measurement points per profile
- ✓ Profile speed up to 200 kHz
- ✓ Embedded high-precision 3D profiling
- ✓ Enhanced 3D imaging with HDR 3D technology
- ✓ Factory calibrated devices
- ✓ Ruggedized enclosure (IP67)
- ✓ Advanced 3D scan features like Autostart, Automatic AOI Tracking and Multiple AOIs
- ✓ Free SDK for image acquisition, 3D point cloud generation, extrinsic calibration and z-Map creation





## Fast, Accurate 3D Imaging for Industry

*The speed of production processes and the quality requirements are steadily increasing, and therefore the industry is demanding suitable up-to-date measuring technologies. Even if 3D scanning has already been established as a reliable solution for a lot of applications, some industries still consider its potential as not sufficient for their testing challenges.*

*Usually, the most critical factors are the measuring accuracy and speed – precisely the disciplines in which the CS 3D compact sensors are in a class of their own. They not only feature up to 4,096 measurement points per profile but also operate at a measurement speed of up to 200 kHz, which allows a maximum output of 200,000 profiles per second.*

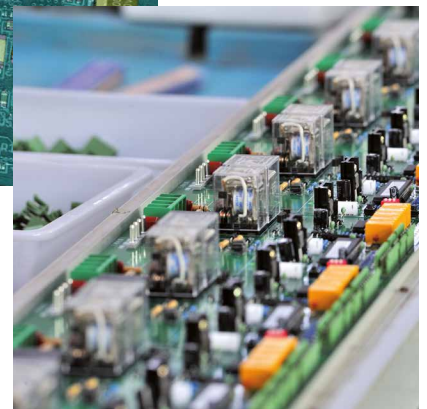
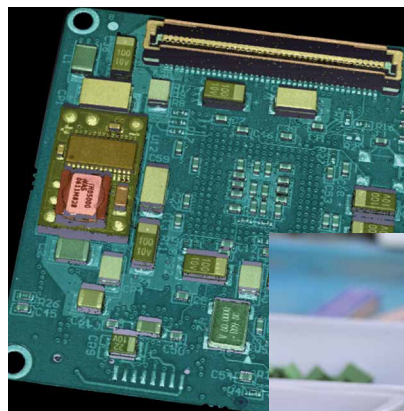

## Cutting-Edge 3D Imaging Technology

The CS sensors scan measurement objects using the laser triangulation principle. The object passes through an area on which a laser line is projected, and the laser line runs along the surface of the object. A CMOS imager records the course of the laser line from a predefined angle and produces corresponding images of cross-sectional profiles. Using state-of-the-art FPGA technology, the CS sensors achieve their maximum profile speed independently of the chosen line detection algorithm.

They are the first 3D compact sensors with 4K Ultra HD resolution. In addition, all CS models have a Gigabit Ethernet interface and comply with the GigE Vision standard, which allows a fast and uncomplicated connection to any common image processing software. For the large variety of application requirements, we offer two sub-series of 3D compact sensors, the C5-CS series of pre-configured models and the MCS series of modular configurable sensors.

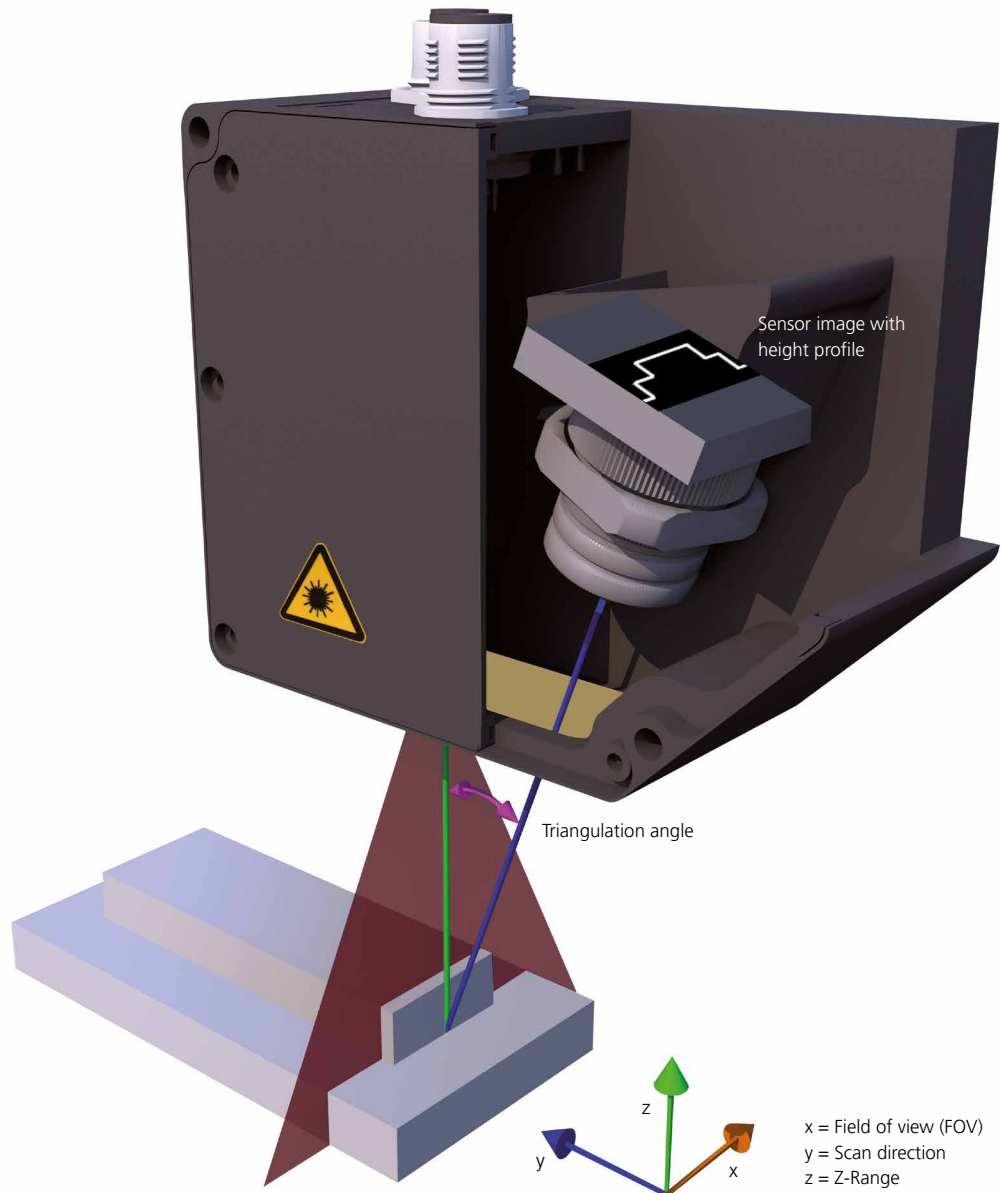

## C5-CS Series – the Suitable 3D Compact Sensor for every Need

The C5-CS series combines the well-established laser triangulation cameras of AT's C5 series with state-of-the-art laser electronics in a compact design. In order to provide solutions for a variety of applications, it comprises a wide range of models with different sensors and housings. Thus, it offers factory calibrated 3D compact sensors with precisely the characteristics in terms of field of view, height measuring range, lateral and height resolution that you need for your measuring task.

For a reliable operation even in the roughest industrial environments, all C5-CS models feature a ruggedized IP67 housing. The cable connections are equipped with M12 tensile- and tear-resistant connectors, which ensures a secure power supply and data transfer.



### Model 1

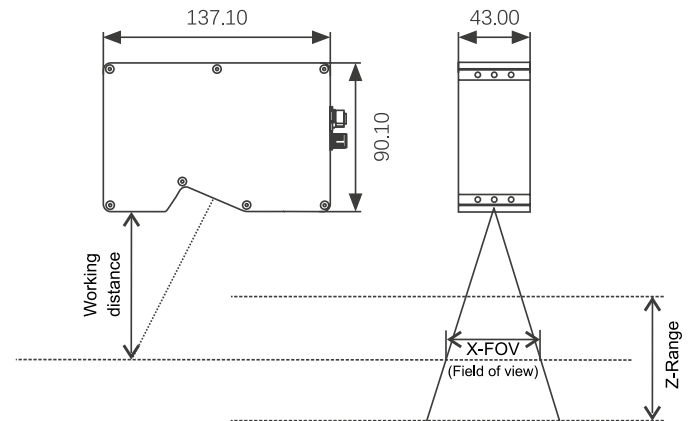

Model name	X-FOV [mm]	Z-Range [mm]	Working distance [mm]	Resolution X [μm]	Resolution Z [μm]	Points per profile	Max. profile speed [Hz]	Linearity [% of Z-Range]	Repeatability [μm]
C5-1280CS23-29	29	40	106	23	0.8	1,280	200,000	±0.01	0.4
C5-1600CS23-30	30	40	106	19	0.7	1,600	25,000	±0.01	0.5
C5-2040CS23-38	38	40	106	19	0.7	2,048	25,000	±0.01	0.5
C5-1280CS23-47	47	40	106	37	1.4	1,280	200,000	±0.01	0.5
C5-1600CS23-49	49	40	106	31	1.2	1,600	25,000	±0.01	0.7
C5-2040CS23-63	63	40	106	31	1.2	2,048	25,000	±0.01	0.7
C5-1280CS23-75	75	40	106	59	2.3	1,280	200,000	±0.01	2.0
C5-1280CS14-76	76	80	197	59	3.5	1,280	200,000	±0.01	1.6
C5-1600CS23-78	78	40	106	49	1.9	1,600	25,000	±0.01	1.0
C5-2040CS23-100	100	40	106	49	1.9	2,048	25,000	±0.01	1.1
C5-2040CS14-100	100	120	197	49	2.9	2,048	25,000	±0.01	3.0
C5-1280CS14-120	120	120	197	94	5.9	1,280	200,000	±0.01	3.7
C5-1600CS14-125	125	80	197	78	4.9	1,600	25,000	±0.01	3.7
C5-2040CS14-160	160	80	197	78	4.9	2,048	25,000	±0.01	6.6

Model **2**

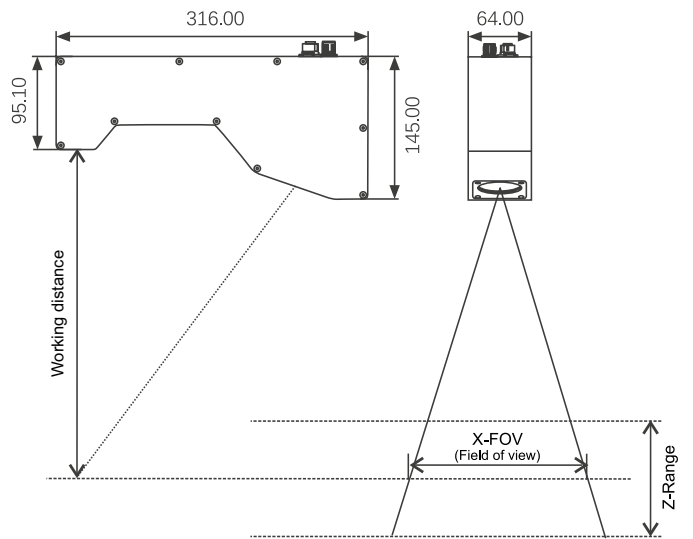

Model name	X-FOV [mm]	Z-Range [mm]	Working distance [mm]	Resolution X [ $\mu\text{m}$ ]	Resolution Z [ $\mu\text{m}$ ]	Points per profile	Max. profile speed [Hz]	Linearity [% of Z-Range]	Repeatability [ $\mu\text{m}$ ]
C5-4090CS30-182	182	250	400	44	1.4	4,096	14,500	$\pm 0.01$	2.1
C5-1280CS30-248	248	300	400	194	6.1	1,280	200,000	$\pm 0.01$	3.1
C5-1600CS30-260	260	300	400	163	5.1	1,600	25,000	$\pm 0.01$	2.5
C5-4090CS30-288	288	300	400	70	2.2	4,096	14,500	$\pm 0.01$	1.2
C5-4090CS19-302	302	500	700	74	3.5	4,096	14,500	$\pm 0.01$	2.8
C5-2040CS30-330	330	300	400	161	5.0	2,048	25,000	$\pm 0.01$	2.6
C5-1280CS19-480	480	500	700	375	18	1,280	200,000	$\pm 0.01$	12.0
C5-4090CS18-490	490	800	744	120	6.0	4,096	14,500	$\pm 0.01$	5.0
C5-4090CS30-495	495	300	400	121	3.8	4,096	14,500	$\pm 0.01$	2.2
C5-1600CS19-500	500	500	700	313	15.0	1,600	25,000	$\pm 0.01$	10.0
C5-2040CS19-640	640	500	700	313	15.0	2,048	25,000	$\pm 0.01$	10.0
C5-1600CS18-795	795	800	744	496	25.1	1,600	25,000	$\pm 0.01$	8.4
C5-4090CS18-842	842	800	744	206	10.4	4,096	14,500	$\pm 0.01$	10.0
C5-2040CS18-1015	1,015	800	744	496	25.1	2,048	25,000	$\pm 0.01$	8.4
C5-2040CS15-1200	1,200	1,090	920	586	35.3	2,048	25,000	$\pm 0.01$	10.0

# C5-CS Series

## Model 3

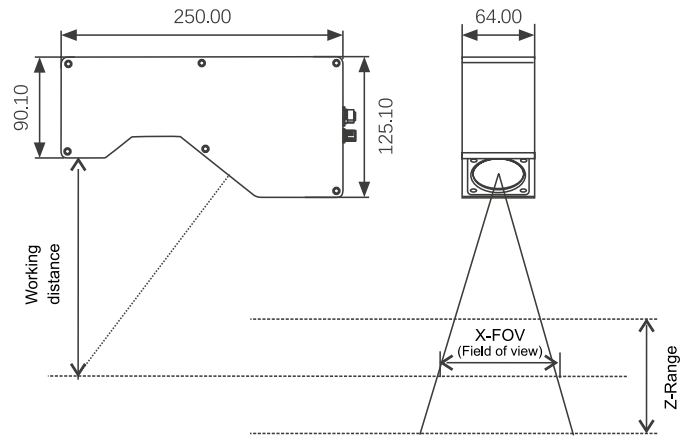

Model name	X-FOV [mm]	Z-Range [mm]	Working distance [mm]	Resolution X [ $\mu\text{m}$ ]	Resolution Z [ $\mu\text{m}$ ]	Points per profile	Max. profile speed [Hz]	Linearity [% of Z-Range]	Repeatability [ $\mu\text{m}$ ]
C5-4090CS39-82	82	15	172	20	0.5	4,096	14,500	$\pm 0.01$	0.4
C5-4090CS39-145	145	15	172	35	0.9	4,096	14,500	$\pm 0.01$	0.7

## Model 4

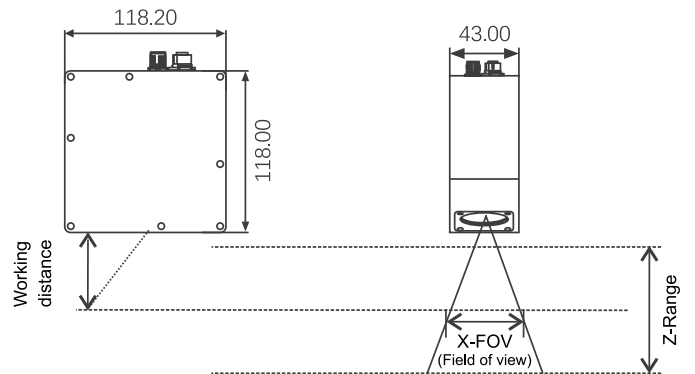

Model name	X-FOV [mm]	Z-Range [mm]	Working distance [mm]	Resolution X [ $\mu\text{m}$ ]	Resolution Z [ $\mu\text{m}$ ]	Points per profile	Max. profile speed [Hz]	Linearity [% of Z-Range]	Repeatability [ $\mu\text{m}$ ]
C5-2040CS30-12	12	6	51.5	5.5	0.2	2,048	25,000	$\pm 0.02$	0.2

Model **5**

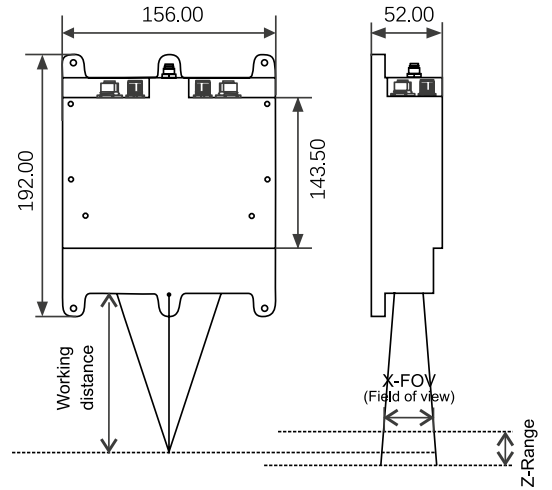

Model name	X-FOV [mm]	Z-Range [mm]	Working distance [mm]	Resolution X [ $\mu\text{m}$ ]	Resolution Z [ $\mu\text{m}$ ]	Points per profile	Max. profile speed [Hz]	Linearity [% of Z-Range]	Repeatability [ $\mu\text{m}$ ]
C5-2040CS18-38-2X	38	30	117	19	0.83	2,048	25,000	$\pm 0.02$	0.7

Model **6**

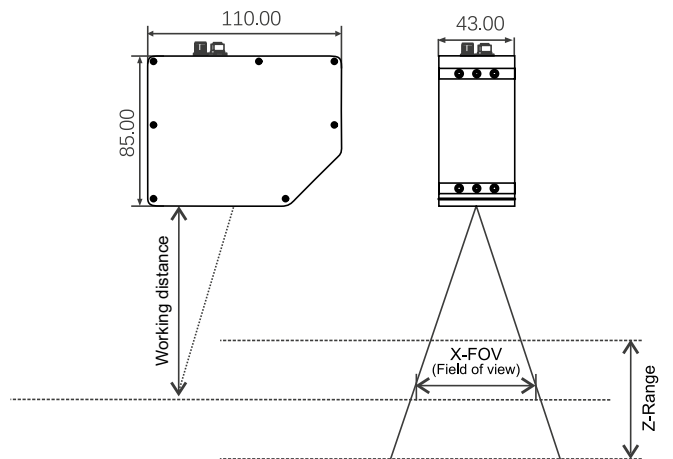

Model name	X-FOV [mm]	Z-Range [mm]	Working distance [mm]	Resolution X [ $\mu\text{m}$ ]	Resolution Z [ $\mu\text{m}$ ]	Points per profile	Max. profile speed [Hz]	Linearity [% of Z-Range]	Repeatability [ $\mu\text{m}$ ]
C5-1280CS35-7	7	5.2	31	5	0.2	1,280	200,000	$\pm 0.02$	0.2
C5-1280CS35-12	12	8	31	10	0.2	1,280	200,000	$\pm 0.02$	0.1
C5-1280CS25-20	20	20	72	16	0.5	1,280	200,000	$\pm 0.02$	0.2
C5-1280CS21-40	40	46	90	31	1.2	1,280	200,000	$\pm 0.02$	0.4
C5-2040CS21-53	53	46	90	26	1.0	2,048	25,000	$\pm 0.02$	0.5

## MCS Series – Modular 3D Compact Sensors, “Specified by You – Provided by AT”

While the C5-CS series comprises a wide range of pre-configured models, the MCS series allows customers to configure the solutions required for their applications themselves. The customer simply specifies the desired data such as height resolution, working distance, scan width (x-FOV), points per profile, profile speed as well as laser wavelength and class. Then he receives a 3D sensor composed of corresponding modules. He gets this perfectly tailored solution without any extra cost or extra time, even as a single piece. Maximum flexibility without NRE charge – no other manufacturer in the world offers this.

Of course, the 3D compact sensors of the MCS series are factory calibrated and feature everything that is required for industrial use, from a ruggedized IP67 housing to 5 to 24 volt digital inputs and outputs to an RS422 encoder interface.

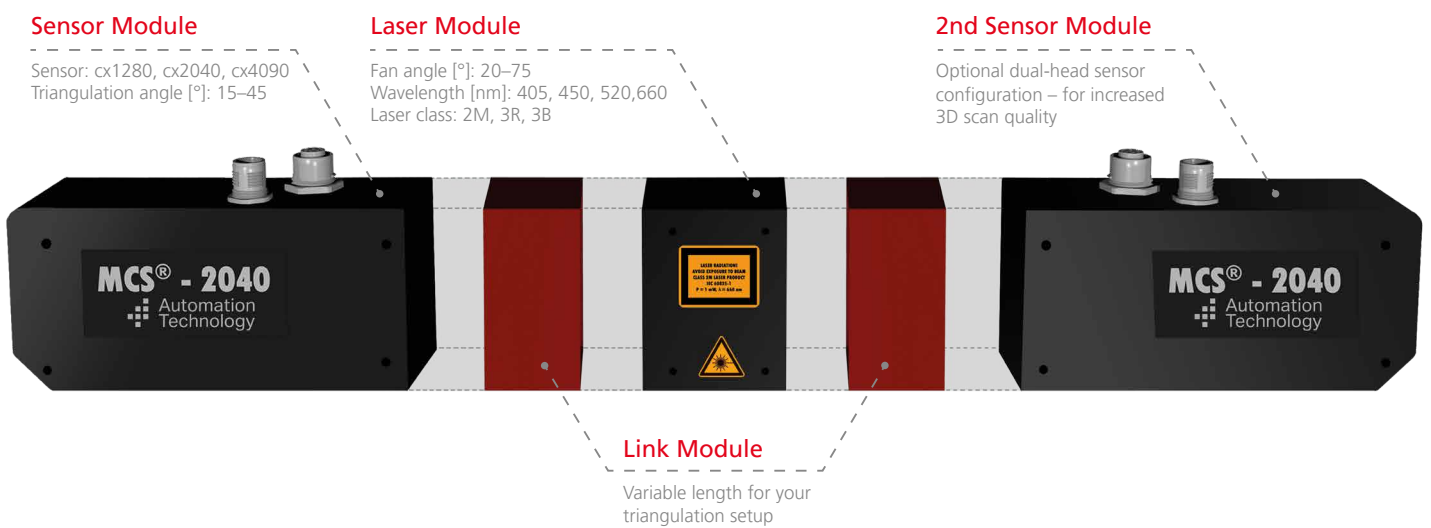

### Optional Dual-Head Sensor for Dual Performance

A major advantage of the MCS series is that all configurations can also be implemented with dual-head sensor, i.e. two sensor modules. This enables even higher measurement quality thanks to occlusion-free 3D scans as well as the combination of sensor modules with different performance data that complete different measurement tasks in parallel. Thus, uncomplicated tailor-made solutions are also available for all applications in which several component properties are examined, for example, the geometry and surface condition of wood parts. Time-consuming installations with several standard individual sensors that have to be calibrated specifically for their respective measurement task are a thing of the past. In summary, the MCS series offers an impressive package of advantages:

- ✓ Modular configurable to perfectly meet your demands in terms of FOV, resolution and speed
- ✓ No NRE charge for customization
- ✓ Optional dual-head sensor for increased 3D scan quality
- ✓ All configurations are factory calibrated
- ✓ Robust design for maximum reliability

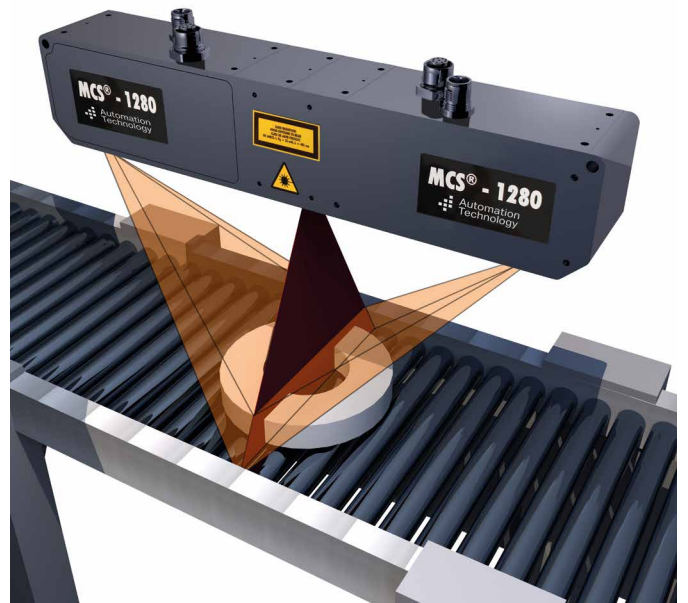



## Sensor Modules

Type	cx1280	cx2040	cx4090
Points per profile	1,280	2,048	4,096
X-FOV [mm]	25–1,800	35–1,800	90–1,800
Triangulation angle [°]	15, 20, 25, 30, 45	15, 20, 25, 30, 45	15, 20, 25, 30
Resolution X [μm]	20–1,400	17–900	22–440
Resolution Z [μm]	1–30	1–20	1–14
Z-Range [mm]	40–1,500	35–1,500	100–1,500
Linearity [% of Z-Range]	±0.01	±0.01	±0.01
Repeatability [μm]	1–100	1–100	1–100
Max. profile speed [kHz]	200	25	14.5
Module size [mm]	115 x 60 x 110 (L x D x H) 130 x 60 x 60 (L x D x H)	115 x 60 x 60 (L x D x H) 130 x 60 x 60 (L x D x H)	110 x 60 x 100 (L x D x H)

## Laser Modules

Type	cx405	cx450 (on request)	cx520 (on request)	cx660
Wavelength [nm]	405	450	520	660
Fan angle [°]	20, 30, 45, 60, 75	20, 30, 45, 60, 75	20, 30, 45, 60, 75	20, 30, 45, 60, 75
Working distance [mm]	128–1,500	128–1,500	128–1,500	128–1,500
Power [mW]	25–160	20–75	20–60	20–130
Safety class	2M, 3R, 3B	2M, 3R, 3B	2M, 3R, 3B	2M, 3R, 3B
Line thickness [μm]	60–600	60–700	90–990	90–990
Module size [mm]	44 x 60 x 60 (L x D x H)	44 x 60 x 60 (L x D x H)	44 x 60 x 60 (L x D x H)	44 x 60 x 60 (L x D x H)

## Link Modules

Length [mm]	0, 15, 30, 45, 65, custom length
-------------	----------------------------------

## Electrical and Data Interface

External trigger functions	Encoder, 2 IN, 2 OUT
Power supply [V]	10–24
Power consumption [W]	10
Power connector	17-pin M12 connector
Ethernet connector	8-pin A-coded M12 connector
Data interface	GigE Vision, GenIcam
Protocols	GigE Vision, HTTP, mDNS

## Environmental

Protection degree	IP67
Operating temperature [°C]	0–50 (non condensing)
Shock	15 g (IEC 60068-2-27)
Vibration	2 g, 20–500 Hz (IEC 60068-2-6)



## Optional Laser Configurations

In addition to our standard laser modules, we offer a choice of other lasers that have different powers, wavelengths and laser classes. This extended laser selection enables a reliable and precise determination of profiles, including measurement tasks with special challenges.

Description	Wave-length	Output power	Laser
Blue laser option	405 nm	25 mW	Class 3R
Blue laser option (Thin line)	405 nm	160 mW	Class 3B
Blue laser option	405 nm	160 mW	Class 3B
Red laser option	660 nm	130 mW	Class 3B
Red laser option	660 nm	Depending on model	Class 2M
Blue laser option	405 nm	Depending on model	Class 2M



## I/O Panel

For an easy system integration of the CS sensors, we offer a compact I/O panel for DIN rail mounting that provides all signal and power connections on plug terminals. The connection for the power supply includes a reverse polarity protection and a 2 A micro fuse.



## CX Cable for Power and I/O

The CX cable connects the sensor with the I/O panel. It is tensile and tear-resistant, available in various lengths, and equipped with M12 connectors, supporting protection class IP67. A pigtail version is available if you want to connect sensor power and signals without the I/O panel.



## CX GigE Cable

A reliable Ethernet communication between the CS sensor and connected hardware is ensured by the tensile and tear-resistant CX GigE cable with M12 connectors, supporting protection class IP67. The cable is available in various lengths.



## 90° Adapter Cable

The integration of a CS sensor often takes place in a small space where standard straight and M12 connectors can cause cable routing problems. Our 90° adapter cable is a simple and elegant solution for this.

## AOI Functions

The CS sensors allow the definition of Areas of Interest (AOIs), which increases the scan rate significantly. In addition, they feature a number of functions for a specific AOI use:

### AOI Search

AOI Search automatically finds the laser line in the sensor image and centers it in the AOI. The user only has to define the minimum required AOI height, i.e. the number of required sensor rows, for the expected laser line position. The camera will then re-locate the AOI vertically.

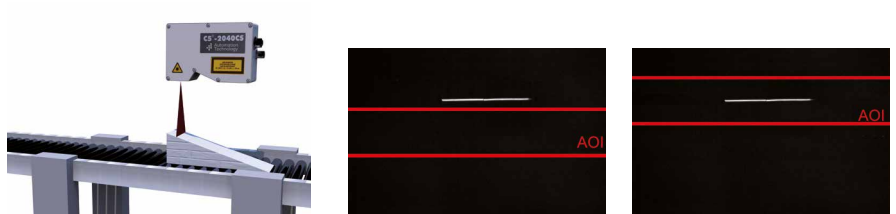

### Automatic AOI Tracking

AOI Tracking automatically tracks the laser line and reduces the AOI to a minimum number of sensor rows. This feature is particularly interesting for applications with continuous profile measurements and a varying distance to the surface of the measured object. It enables precise measurements at an even higher speed.

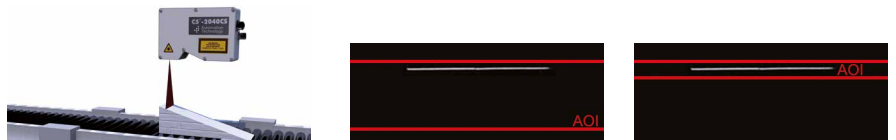

### Multiple Sensor AOIs

The positioning of several AOIs also reduces the number of required sensor rows to a minimum. It is particularly useful for applications with a greater distance between the test-relevant areas and not only avoids the capture of nonrelevant measurement data but also increases the scan rate drastically.



## High Dynamic Range (HDR 3D)

Thanks to the High Dynamic Range functionality, it is possible to scan materials and surfaces with inhomogeneous reflection properties. HDR 3D prevents sensor intensity saturation and expands the dynamic range of the sensor images up to 90 dB. In essence, this technology consists of two independent but combinable sensor functions:

### MultipleSlope Mode

The MultipleSlope mode is used to avoid the saturation of pixels during exposure of the sensor chip. For this purpose, the user can set a limit for the light volume or pixel intensity (saturation threshold) within a predetermined time (exposure limit). After expiration of this time, the pixels can capture more light until the end of exposure. This procedure is known as DualSlope.

It is also possible to repeat the aforementioned procedure a second time (TripleSlope mode). The intensity limits and time in DualSlope and TripleSlope can be configured separately.

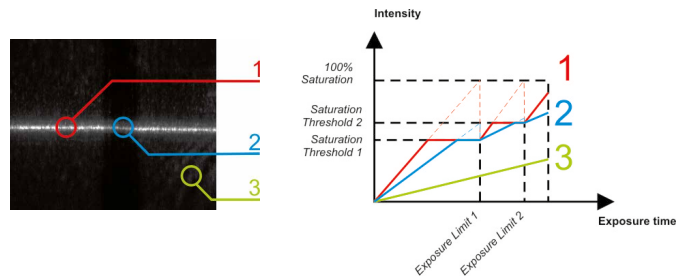
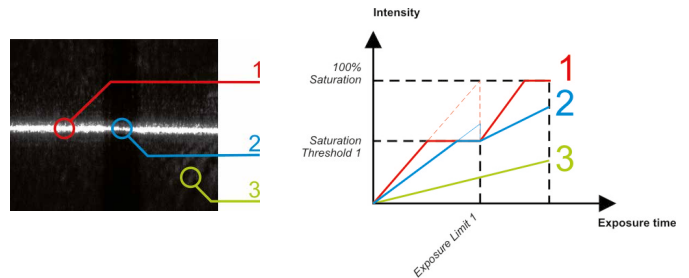
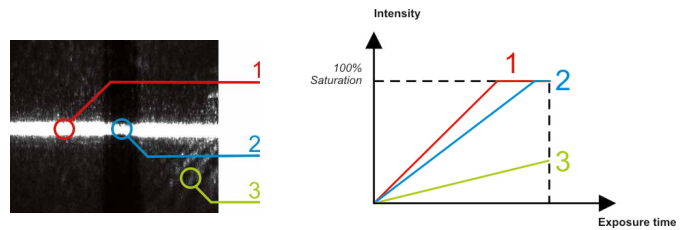

### Multiple Sensor Readout

The Multiple Sensor Readout function enables up to four imager readouts during exposure time. The user only has to predefine individual exposure times for the readouts. It is then possible, for example, to read out recordings of highly reflective objects with

a short exposure time and darker image areas with a longer exposure time. Subsequently, the partial images can be combined to generate a homogeneous and saturation-free image.

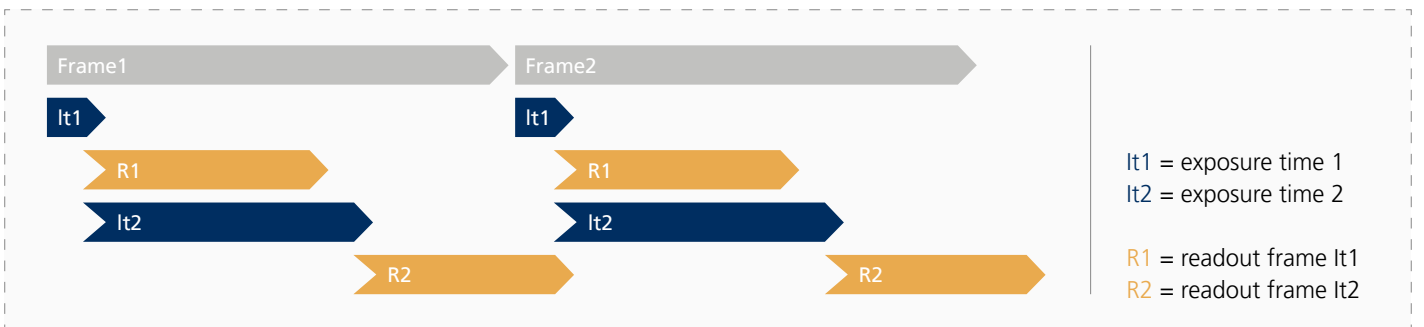

# Advanced Triangulation Algorithms

In order to determine a profile, the position of the laser line in the sensor image is evaluated column by column. The Gaussian intensity distribution along a column is used to find the exact line position in the column.

For this purpose, the CS sensors come with a range of evaluation algorithms that have different strengths and allow more flexible solutions to meet the application-specific requirements. In addition to the basic MAX (maximum) and TRSH (threshold) algorithms, there are the COG (center of gravity) and FIR-PEAK algorithms that provide high-precision 3D measurement results. In contrast to competitive products, the choice of the algorithm does not influence the profile speed of the CS sensors.

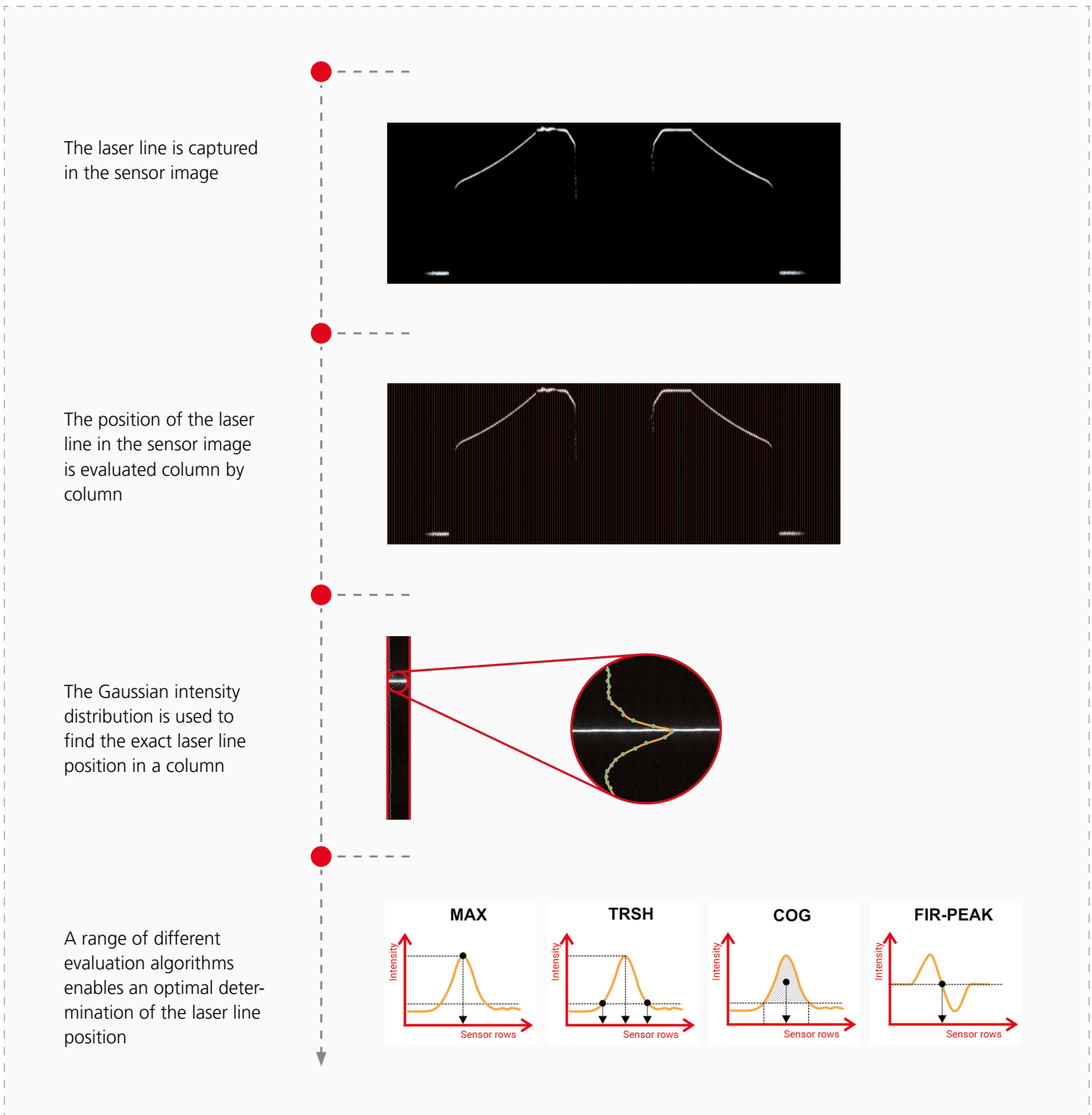

## Subpixel Accuracy

All CS sensors have a subpixel accuracy of 1/64 pixel, which is to say that profiles can be determined more precisely by 64 times. This is valid even at a profile rate of 200 kHz, depending on the model.

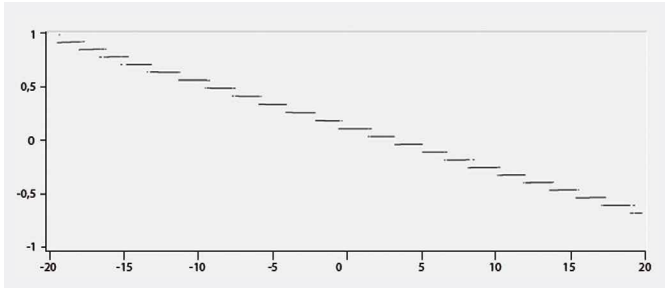

Without subpixel accuracy

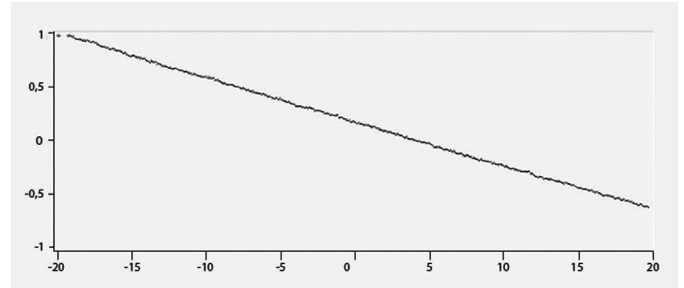

With subpixel accuracy (1/64)

## Scheimpflug Setup

In order to compensate the loss of image focus caused by the triangulation geometry, the sensor and lens in the housing are arranged according to the Scheimpflug principle. The sensor/image plane is in opposite tilt angle to the objective/object plane. Thus, the depth-of-field effect is automatically eliminated, and the laser line is sharply displayed in the sensor image.

Result image without Scheimpflug setup

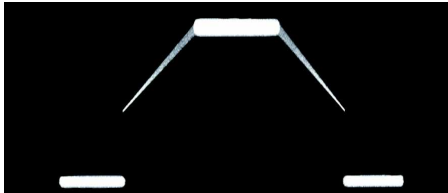

Result image with Scheimpflug setup

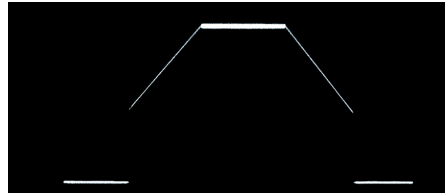

## Autostart

In the Autostart mode, the CS sensors automatically detect the measurement object and trigger a recording process in which the object is scanned. Thanks to the optional access to the history buffer, pretrigger profiles can be added for a complete scan. Therefore, the installation requires no additional components like a light barrier to initiate the recording process.

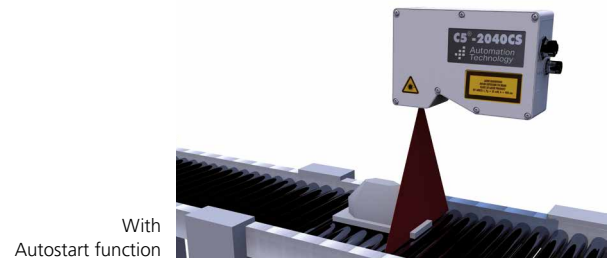
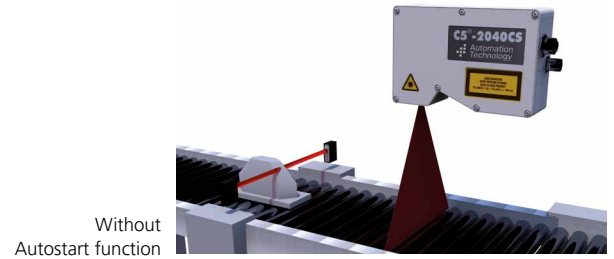

## Enhanced Encoder Interface

The CS sensors feature an RS422 camera interface to support differential and asymmetrical signal transmission. A special feature also enables profile triggering using TTL pulse sequences and, consequently, the use of single-ended or single-channel encoders. Applications can thus access information about trigger speed or direction without the need of two channel differential encoders. In addition, the camera can forward the trigger signals directly to an output, which means that an oscilloscope for debugging/monitoring when a system is commissioned can be used. The output signal can also be delayed or inverted, and the pulse width can be adjusted, for example, to enable master-slave operation between two or more CS sensors.

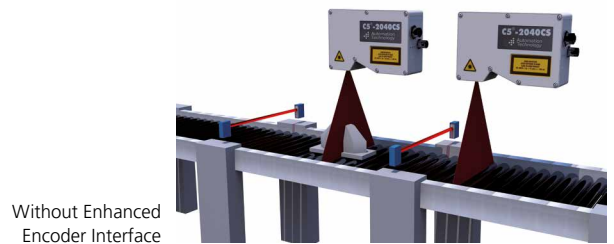

## Multiple Feature Output

Equipped with multiple data output channels, the CS sensors can provide different information at the same time. This allows the user to examine different object features by checking three images simultaneously: height data, intensity and laser scatter.

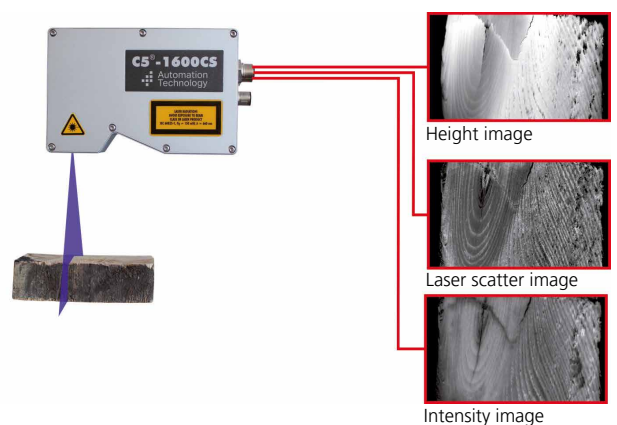

## The Perfect Toolbox for Your Application

The CS series is part of the AT Vision World with its smart camera platform that also forms the core of our 3D compact sensors. The AT Vision World offers a most comfortable user environment. This includes a variety of tools, standard APIs, and apps that provide OEMs and machine builders with both easy-to-use and in-depth access to the CS sensors. Thus, the sensors can be flexibly adapted to customer-specific requirements and quickly and easily integrated into new or existing systems.

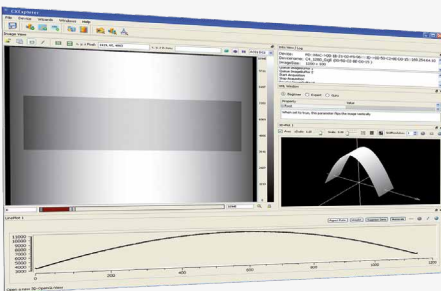
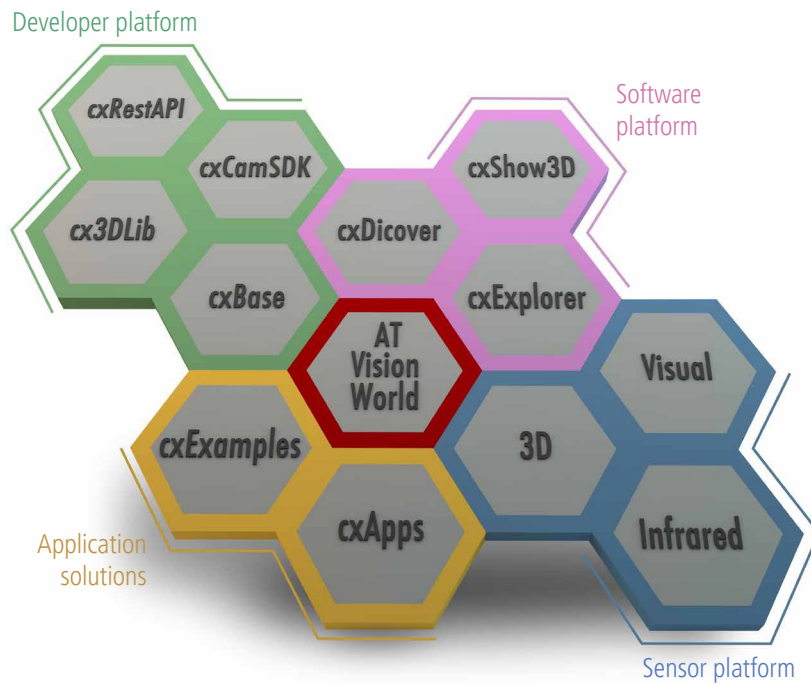

### 3DExplorer

The 3DExplorer is a configuration and recording software for the CS sensors. By directly accessing the internal memory of the sensor, it allows saving of the configuration settings on the computer and the sensor. Beyond that, the 3DExplorer enables recorded measurement data to be saved in various formats such as 3D point clouds.

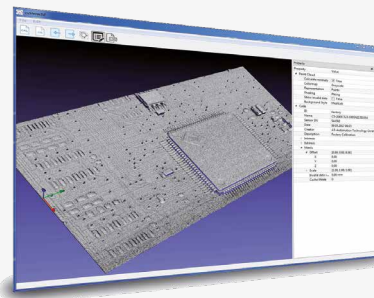

### cxShow3D

cxShow3D enables an optimal visualization of the recorded 3D scans. The graphical user interface makes it easy to create views of point clouds or other measuring data in order to provide the user with detailed visual impressions of the inspected component. It allows the extrinsic calibration of the 3D scanner and the creation of z-Maps for further processing with standard machine vision tools.



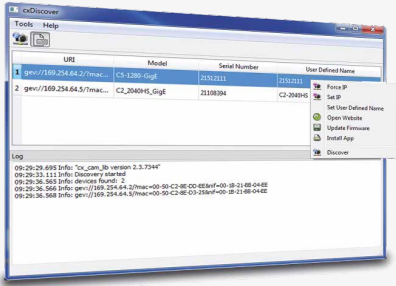

### cxDiscover

cxDiscover recognizes all available 3D sensors of the system environment. Through the graphical user interface, the software enables an easy integration and installation of firmware updates or apps.

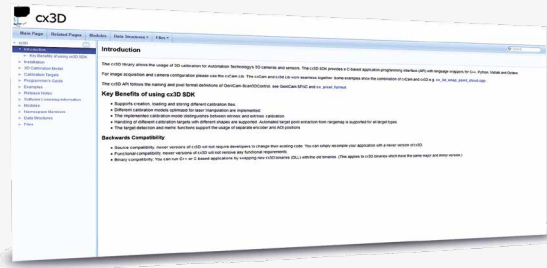

### cx3DLib

cx3DLib allows the usage of 3D calibration for the CS sensors to create, load, and store calibration files. The library features different calibration models optimized for laser triangulation that ensure an easy handling of different calibration targets with different shapes. cx3DLib works seamlessly together with cxCamLib to check the output of the calibration settings. In addition, it contains useful functions for the preprocessing of 3D scans such as 3D point cloud generation and height image rectification (z-Map).

### cxExamples

cxExamples is a unique sample collection that comprehensively explains the individual features of the CS sensors and their use. Besides other functions, it shows the user how to load and convert calibration files, how to read and write chunk data, how to iterate on a GenICam nodemap, or what steps are necessary to perform a continuous image acquisition.

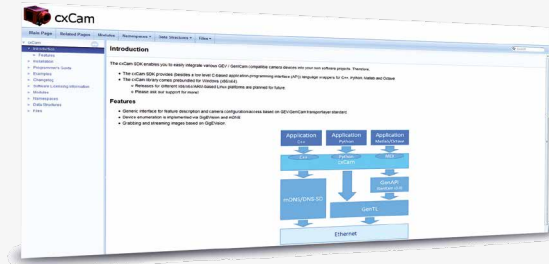

### cxCamSDK

cxCamSDK enables an easy integration of the CS sensors into software projects. It provides a C-based application-programming interface (API) and language wrappers for C++, Python, MATLAB, and Octave and comes with a generic interface for feature description and sensor configuration/access based on the GEV/GenICam transport layer standard.



### cxSmart-Apps

The cxSmart-App solutions enable an easy implementation of 3D vision applications and particularly aim at integrators without experience in the field of 3D imaging. Due to preprogrammed processes, the operator only needs to adjust the parameter setup via an application-optimized user interface to put solutions like pin inspections into practice. As part of the measurement, the collected data can be automatically evaluated, and the results can then be sent to downstream instruments.

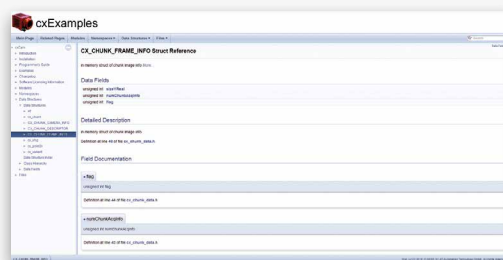

# Applications

## Tire Inspection

The 3D inspection of tires is a typical application of the CS sensors in the automotive industry. Since even the smallest surface defects can have an impact on driving quality and safety, a precise quality control is imperative in tire production. This is why our 3D compact sensors are not only used for tire profile defect detection and nub height measurement but also for recognition of tire markings.

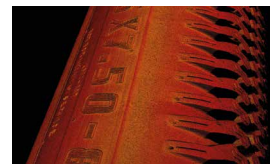

## Train Inspection

Since trains have enormous operating times, fast and precise maintenance work is required to ensure a safe operation. The CS sensors help to find missing, broken, or deformed components in train bogies and chassis. Thanks to their high speed, even measurements on passing trains are possible. Railway companies also use our 3D compact sensors to assess the condition of rail heads when testing the rail network.



## Weld Seam Inspection

The CS sensors are excellent in many respects to assess the quality of welding processes. The three-dimensional measurement data help not only to detect weld seams but also provide information about their height, width and volume. In addition to the shape, the correct position of the weld seams can also be checked by the measuring principle of laser triangulation.

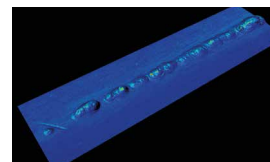
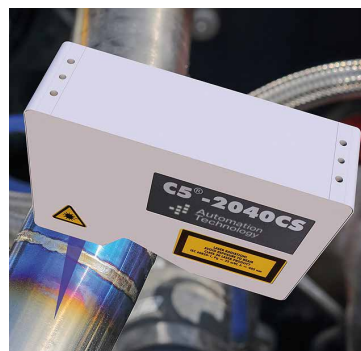

## Inspection of Electronic Components

Another industrial sector that often relies on the CS sensors is the electronics and semiconductor industry. Typical test objects are circuit boards, ball grid arrays (BGAs), or connectors, whose flatness and complanarity are checked. Our 3D compact sensors detect even the smallest deviations from the target.

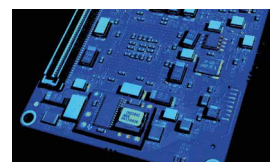

### Surface Inspection

For many products such as mobile devices or other consumer items, haptics can influence the purchase decision. In order to prevent quality deficiencies in this area, many manufacturers use the laser triangulation method for the surface testing of their products. With the CS sensors, even flaws in the micrometer range can be detected, and unevenness of product surfaces is no longer an issue.

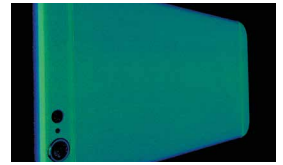

### Wood Inspection

In the wood industry, scanings of the wood surface can provide information about various quality factors. A big challenge in testing is the combination of a fast throughput of test objects and relatively wide scanning ranges. These are typical applications in which the CS sensors demonstrate their strengths and deliver measurement results of an unbeatable precision.

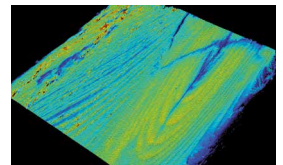

### Packaging Control

In industries such as the food and pharmaceutical sector, a flawless packaging is of the utmost importance. Air-tight packagings are often required to ensure compliance with the minimum use-by date. For this purpose, very precise tests are carried out in order to guarantee, for example, a seamless welding. The CS sensors with their high measuring accuracy are ideal for these applications.

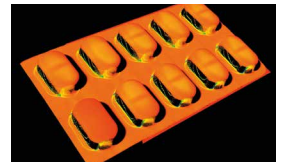

### Inspection of Plastic Components

In the production or processing of plastic components, small irregularities or microcracks are sufficient to render a product unusable. Quality tests are often challenging due to complex geometries. The laser triangulation procedure, which masters even the most complex structures and detects even the smallest flaws, provides an optimal solution for these challenges.





AT – Automation Technology GmbH

Hermann-Bössow-Str. 6–8  
23843 Bad Oldesloe  
Germany

Phone: +49 (0)4531 88011-0  
Fax: +49 (0)4531 88011-20

Email: [info@automationtechnology.de](mailto:info@automationtechnology.de)  
Web: [www.automationtechnology.de](http://www.automationtechnology.de)