

# NanoCam HD

## 4D Technology

### **Dynamic Surface Roughness Profiler**

#### **Portable, Precise Roughness Metrology**

The NanoCam™ HD dynamic profiler measures surface roughness on small to meter scale coated and uncoated optics, precision metals, plastics, and other polished specular surfaces with sub-angstrom level repeatability and precision.

Providing unmatched flexibility, the light weight NanoCam HD can be easily positioned on large parts by hand, or mounted on a gantry or robotic arm to measure

- anywhere on large, complex objects
- inside production stations and polishing equipment
- multiple parts arrayed on a table
- directly on large optics

Portability and on-machine capability significantly reduce the handling and transportation of large optics, increases throughput and dramatically reduces the risk of damage to expensive, critical optics.

#### **Simple Operation**

New autofocus capability allows for faster, more consistent measurements requiring fewer manual adjustments. Measure parts with reflectivity from 0.5% to 100% without changing reference optics. Single cable, power over ethernet operation can be combined with high speed innovative software for data acquisition and analysis in a laptop environment for added portability.

Utilizing a Linnik configuration, NanoCam HD interference objectives provide superior lateral resolution over a larger field of view with greater working distance and surface measurement fidelity than comparable Mirau objectives.



NanoCam HD with optional tripod

#### **Optional Robot Package**

This dynamic surface roughness profiler quickly integrates to popular collaborative robots from Fanuc™ for rapid data acquisition and automatic data logging along programmed measurement paths. On a robot, the profiler can measure inside a large volume, across a large plane or sphere, on large, complex shapes—even upside down.

#### **Vibration Insensitive Performance**

The NanoCam HD's Dynamic Interferometry® uses a high resolution camera and patented instantaneous phase sensor. A typical acquisition can be thousands of times faster than a conventional optical profiler enabling measurement without vibration isolation. Ideally suited for mounting in polishing equipment, on robots, or placed directly on optics.

#### **Industry Leading Analysis, Standard**

New 4Sight Focus™ analysis software features a user-friendly interface for rapid data acquisition and analysis of ISO 25178 S (surface roughness) parameters. Intuitive masking and filtering make it easy to investigate and quantify surface structure and roughness features.

#### **Accessories**

Select from 0.9X through 20X LWD objectives. Glass-compensated objectives make measurements through cover glass. 50X objectives may be custom ordered. Accessorize with a motorized, joystick controlled tripod, mobile workstation, or interfaces for polishing equipment, gantries or robots.

### **FEATURES**

- Vibration insensitive dynamic operation
- 5 Megapixel, 12-bit, low-noise camera
- High speed auto-focus
- 460 nm pulsed LED source
- Motorized, joystick controlled tip/tilt/Z tripod
- Workstation, gantry, robot mountable Interfaces

### **APPLICATIONS**

- Portable ISO 25178 roughness measurement for optics
- 3D, sub-angstrom measurements on optics of any size
- On-machine polishing measurements, or inside automated metrology cells

# NanoCam™ HD

## Specifications

Configuration	NanoCam HD
Description	Vibration insensitive dynamic surface profiler
Acquisition Mode	Pixelated phase sensor
Light Source	Pulsed LED at 460 nm
Sample Reflectivity	0.5%–100%
Camera	5 Mpix, 3.45 µm pixels, 12-bit
Fine Focus	Motorized autofocus
Computer System	High performance PC with 22 in LCD monitor / Laptop optional
Operating System	Windows® 10
System Software	4Sight™ Focus Analysis Software
	Instantaneous phase shifting data acquisition
	ISO 25178, ASME B46.1-2019 surface roughness parameters, PV, Ra
	2D profiles and 3D surface maps
	Reference generation, subtraction, data averaging
	.4D data format standard, others supported
	including: h5, .opd, .dat, .csv and .txt
	in robotic environment, database automatically logs data
	Upgrades free during warranty period
Physical Envelope	<25 x 25 x 9 cm (9.6 x 9.6 x 3.3 in)
Weight	< 5.3 kg (11.5 lbs)
Power Consumption	< 12 Watts instrument
Temperature Range	Operational: 16–27° C (60–80° F), non-condensing
	Storage: -1–38° C (30–100° F), non-condensing

Options	
Objectives	Long working distance, interferometric objectives
	See table below; other magnifications, or glass compensation, optional
Configurations	Optional joystick-controlled tripod with ± 7° tip/tilt, ± 19 mm (0.75 in) z travel; mobile workstation; dovetail or Schunk mount for robots, gantries, or on-machine interfaces
Calibration Mirror	<1 Å super-smooth mirror
Extended Cables	5 m standard, 10 m optional

System Performance	
Minimum Exposure	< 28 µsec
Vertical Range	115 nm step max
RMS Repeatability <sup>1</sup>	< 0.005 nm
RMS Precision <sup>2</sup>	< 0.1 nm

Long Working Distance Interference Objectives <sup>3</sup>					
Magnification	0.9X	2.0X	5X	10X	20X
Configuration	Michelson	Michelson	Linnik	Linnik	Linnik
Numerical Aperture	0.026	0.055	0.15	0.30	0.45
Working Distance (mm)	15.0	23.0	23.0	17.0	4.5
Optical Resolution at 460 nm (µm) <sup>4</sup>	8.8	4.2	1.5	0.77	0.51
Spatial Sampling (µm) <sup>5</sup>	3.8	1.7	0.7	0.35	0.17
Field of View (mm) (long dimension)	9.4	4.2	1.7	0.8	0.42
Depth of Field @ 460 nm (µm)	1059	190.1	22.5	5.4	2.3
Max. Spatial Wavelength (µm) <sup>6</sup>	9445	4250	1800	850	425
Min. Spatial Wavelength (µm) <sup>7</sup>	19	9	3.5	1.7	0.9

Warranty	One-year, limited, on-site system installation and operator training
----------	--

- One sigma for RMS of 10 data sets of calibration mirror, each data set being an average of 32 measurements.
- Average RMS of the difference of 10 data sets between measured surface and the calibrated surface. Each data set is an average of 32 measurements. Calibrated surface is the pixel by pixel average of 10 measurements of calibration mirror.
- Specifications based on 2056 x 2464 array size.
- Optical resolution is based on Sparrow criteria =  $0.5\lambda/NA$
- Spatial Sampling is the camera pixel size divided by objective magnification.
- (Number of pixels \* pixel size) / magnification (IAW ASME B46.1)
- (5 \* pixel size) / magnification (IAW ASME B46.1)

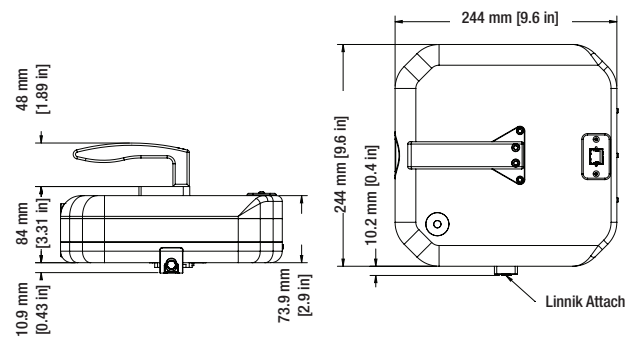
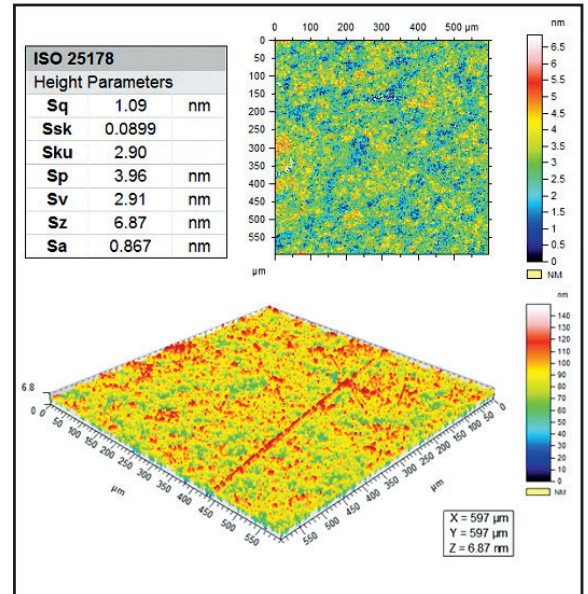

Specifications subject to change without prior notice.

Dynamic Interferometry is a registered trademark, and NanoCam and 4Sight are trademarks of 4D Technology Corporation.

Windows is a registered trademark of Microsoft. All specifications subject to change without notice.

4D Technology Corp is an Onto Innovation subsidiary  
2021.01.05 ■ ©4D Technology Corporation.