

Versatile, High-Performance, Turn-key

Hyperspectral Scanning Solution

The ClydeHSI SC-C80 Hyperspectral Scanning Solution is a complete turnkey hyperspectral solution that includes: spectral camera, scanning stage, interchangeable sample trays, lighting system, focus target, reflectance standard, data acquisition, viewing and analysis software.

ClydeHSI SC-C80 systems have a 220mm wide conveyor belt, are quick and easy to set up on standard tables, and can acquire high resolution spectral images in seconds. The system can operate up to two spectral cameras with simultaneous data acquisition, and is fully compatible with all ClydeHSI hyperspectral cameras and configurations.

Other key features: auto-focus and auto-product height adjustment, fully integrated lighting stage, speed sensors for automatic frame rate calculation for square pixels.



Technical Specifications

Parameter	Value	Units	Comment
Spectral Range	400-2500	nm	Raman options available: consult ClydeHSI
Scanning Area	200 x 200	mm	
Scan Speed	0.2 to 300	mm/s	Automatically synchronised with camera frame rate by software
Camera Stand-off Distance	Up to 700	mm	Fully motorised adjustment via software
Scanner Track Range	Determined by sample length	-	
Feed In/Out	Gravity roller system	-	Option: consult ClydeHSI
Sensors	Speed adjustment for square pixels	-	Automatic
Dimensions	800 x 300 x 1000	mm	L x W x H
Weight	90	kg	

ClydeHSI Hyperspectral Cameras

ClydeHSI manufacture push-broom (line-scan) hyperspectral imaging cameras of high spatial and spectral purity, and measurement systems that are used in a wide range of applications, ranging from scientific research to industrial inspection tasks. These hyperspectral cameras measure a line image one line at a time and register spatial position across the line while simultaneously recording the optical spectrum at each spatial position.

The ClydeHSI SC-C80 is capable of single and dual camera operation with simultaneous data acquisition, and is fully compatible with all ClydeHSI hyperspectral cameras, light sources, and our unique hyperspectral data acquisition and analysis software. This ensures broad adaptability to applications and the capability to capture hyperspectral data from a broad spectral range.

Hyperspectral Camera Options for SC-C80

Parameter	Value					Units
Model	VNIR-S	VNIR-HR	NIR-HR	NIR-HR+	SWIR	
Spectral Range	400-1000		950-1700		1000-2500	nm
Optical Spectral Resolution	8	<3	<5		≤12	nm
Pixels (Spatial Line)	2560		320	640	384	pix
Pixels (Spectral)	2048		256	512	288	pix
Smile and Keystone	Sub-pixel across output field					-
Camera output	Up to 14					bit
Camera Interface	USB-3, GiGe, CameraLINK				Camera LINK	-
Frame Rate	Up to 420		Up to 344	Up to 300	Up to 450	lfps
Shutter	N/A	Integrated				-
Lens mount	C-mount					
Input Voltage	24					V DC

Dimensions

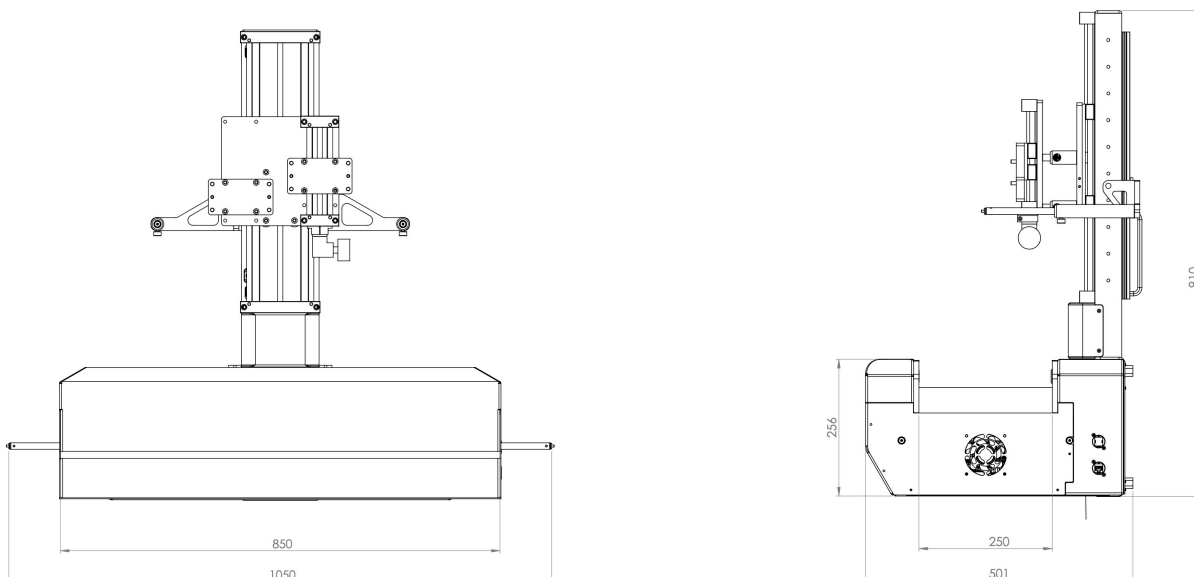

Entry Level System Configuration

Comprising of the following:

- SC-C80 Conveyor Belt Scanner
- VNIR-HR 400 to 1000nm, hyperspectral camera
- NIR-HR+ 950 to 1700nm hyperspectral camera
- Broad-band illumination
- Fore Objective Lens Kit
- Setup, focus, and calibration tiles
- Workstation computer
- Acquisition, visualisation, and analysis software
- Installation and application support.

Optional Accessories

Comprising of the following:

- Auto-focus and auto-product height adjustment
- Machine vision systems for production line use
- Model creation for ultra-high speed, real-time production line sorting/grading applications
- SWIR (1000-2500 nm) hyperspectral camera
- UV (300-400 nm) hyperspectral camera
- Raman hyperspectral camera and laser line illuminators
- LED illuminators

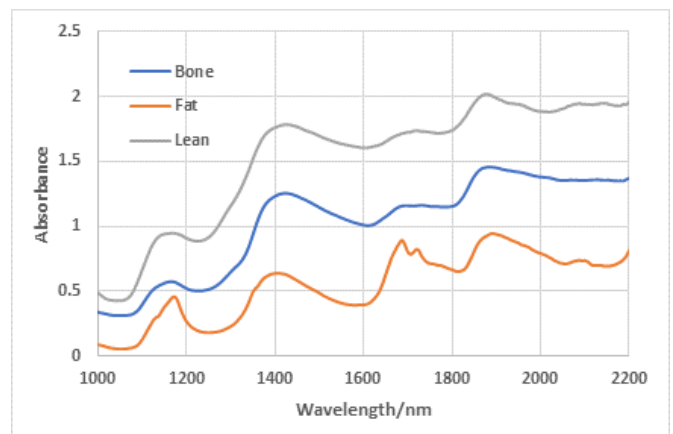
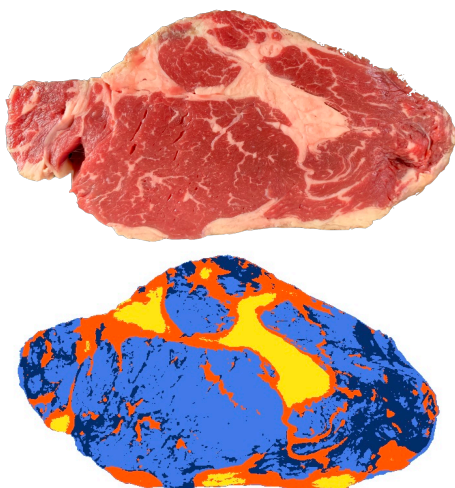

About Us

We make and measure rainbows.

ClydeHSI are specialists in optical spectroscopy and provide a wide range of both hyper-spectral and conventional spectroscopy instruments and full systems. All our products are supported by leading software for data acquisition, analysis and display.

We take care of the technology, so you can focus on what matters to you: the spectroscopy, the imaging and the science.

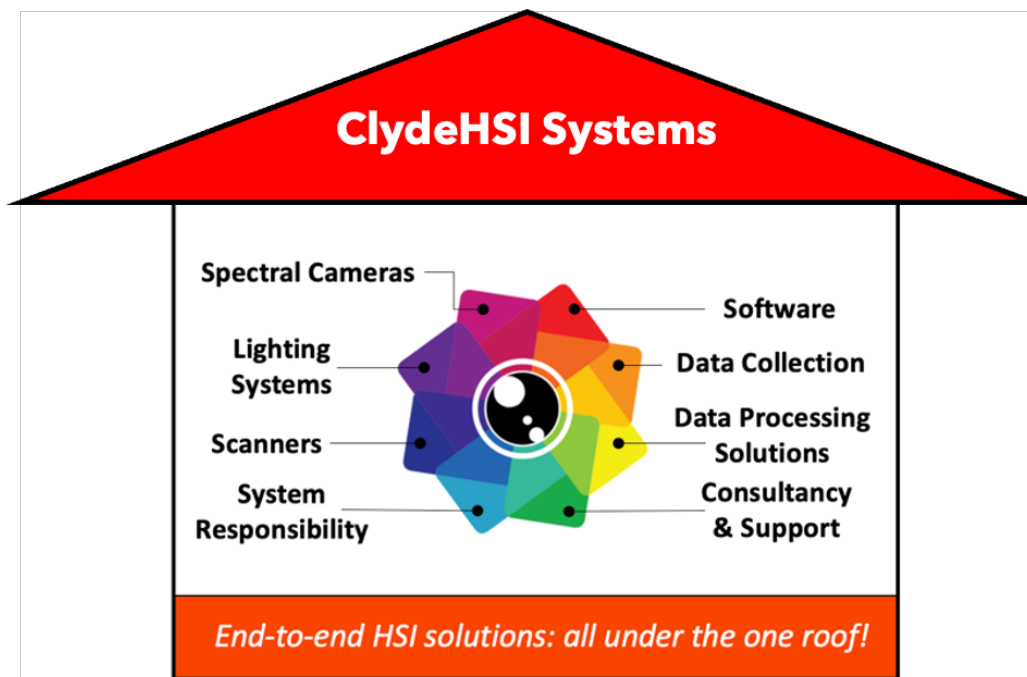

Our mission is to provide each and every one of our clients with a complete, end-to-end hyperspectral imaging solution, designed and rigorously tested to ensure **robust, reliable, accurate and repeatable** hyperspectral imaging measurements across a range of academic and industrial applications. Our ultimate goal for all of our systems is to **make hyperspectral imaging easy** for any and all end users.

We believe in **high quality engineering and design**, allowing us to develop market leading products and services. Within our Photonics Research Facility, we have the capability to rapidly develop new products and systems, and welcome the opportunity to partner with our customers on new developments - both within the scientific research community and for equipment for industrial applications

Headquarters:
1 Aurora Avenue,
Clydebank,
Glasgow, G81 1BF,
United Kingdom

info@clydehsi.com

+44 (0)1419529475

www.clydehsi.com

