

Key Features

- Passive Air-Bearing Rotary Table
- High Load Capacity
- Error Motion < 0.1 μm
- Made of Stainless Steel



Passive Rotary Table EZ-0778

Concept and Design

The EZ-0778 passive rotary table features high axial and radial load capacity and stiffness.

With a low error motion of < 100 nm, this rotary table is ideal for high-precision machining processes.

The air-bearing rotary table can be driven by an external motor using a bellows coupling and pulley; upon request, these components can be pre-assembled at the factory.

There are no restrictions regarding the installation position.

Applications

As drive/bearing in the fields of precision turning, polishing, grinding, wafer grinding; for applications with high demands on concentricity.

Optional Accessories

- Bellows Coupling
- Pulley

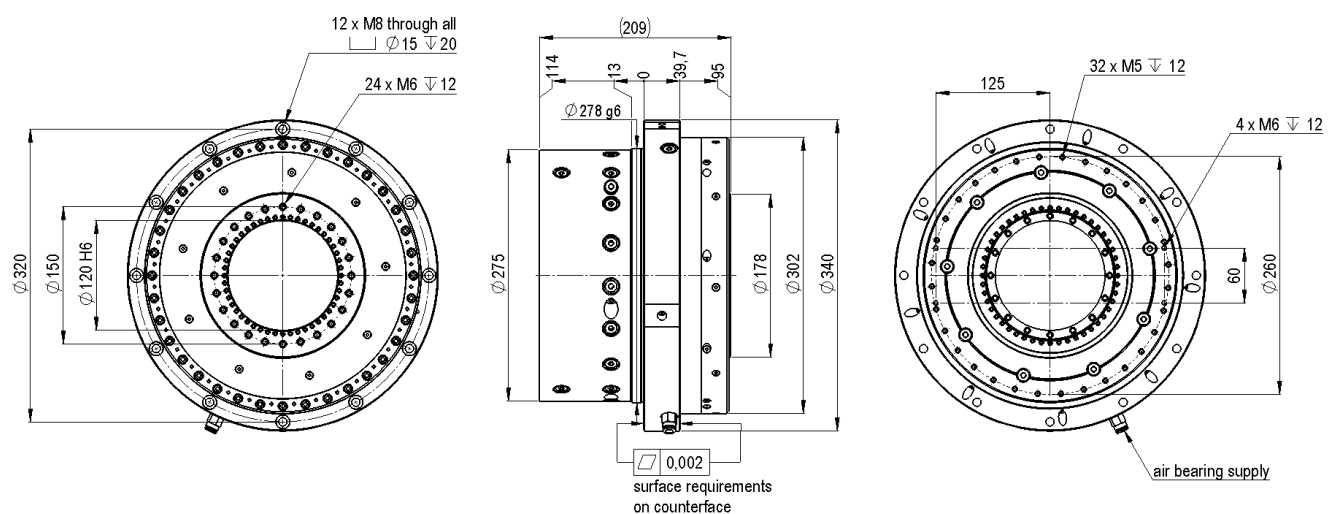

Specifications

Type	Unit	Value
Turning Range	°	> 360 (unlimited)
Error Motion axial (in the center)	µm	< 0.1
Error Motion radial (at 20 mm height)	µm	< 0.1
Runout axial (along radius 85 mm)	µm	< 2
Max. Speed	rpm	1,000
Mechanical Data	Unit	Value
Mounting Position		unrestricted
Diameter x Hight	mm	340 x 209
Max. Load axial	N	3,500
Nominal Load axial push/pull	N	3,000
Max. Load radial	N	2,000
Nominal Load radial	N	1,600
Stiffness axial	N/µm	500
Stiffness radial	N/µm	175
Resistance Against Tilt	Nm/µrad	10
Max. Moment of Tilt	Nm	250
Moving Mass (rotor)	kg	27
Total Mass	kg	90
Inertial Moment (without pulley)	kg*m ²	0.2
Material		stainless steel
Interfaces and Environment	Unit	Value
Supply Pressure	bar	5
Air Consumption	Sl/min	ca. 40
Clean Room Suitability		applicable

Subject to technical modifications and typographical errors.

Datasheet version 2.0

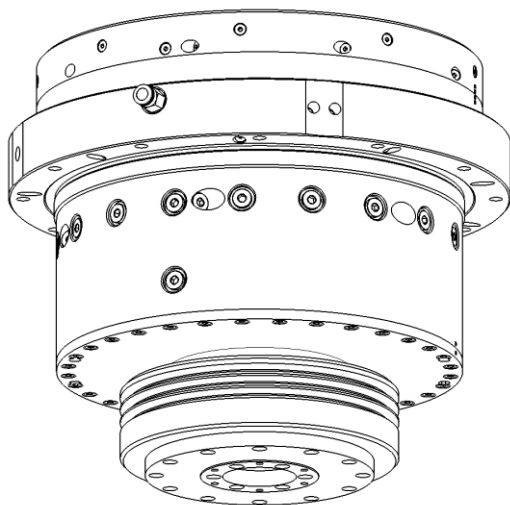

Fig.: Rotary table with pulley
- pulley type as per customer requirements