

Key Features

- Slide 900 x 385 mm (L x B)
- Stroke 2 000 mm
- Payload up to 250 kg
- Incremental Measuring System
- Dynamic Linear Motor
- High Repeatability
- Granite Rail

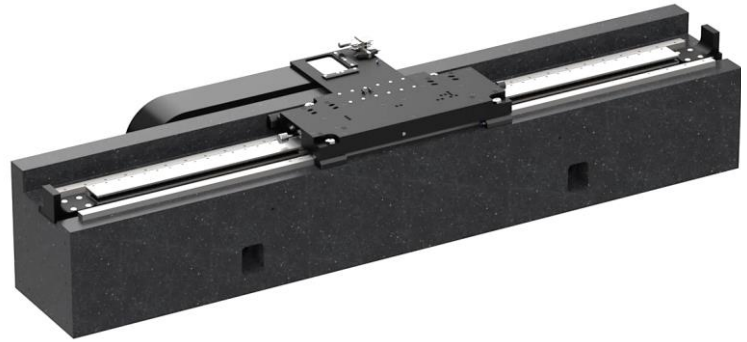

Air-Bearing Linear Axis on Granite Base

Concept and Design

The EZ-2310 linear axis is equipped with a 900 mm long slide, which is magnetically preloaded and runs on a stable granite base.

The linear axis is designed to operate precisely even under high loads and offers plenty of space for customer-specific setups and sensor systems.

A powerful linear motor from Tecnotion (UX12) ensures dynamic slide movement.

In the standard version, the axis is equipped with an incremental measuring system (RSF).

Deviating strokes can be realized on request.

Applications

Inspection technology, sensor and camera positioning for inspection, electronics and PCB manufacturing, AOI (automatic optical inspection), automation processes.

In general: applications with high demands on dynamics, precision, repeatability, smooth scan movements.

Drive Control

We offer the linear axis EZ-2310-2000 with the following drive controllers:

- Kollmorgen Servostar AKD / S300 / S700
- ACS Controller
- Triamec TSD350

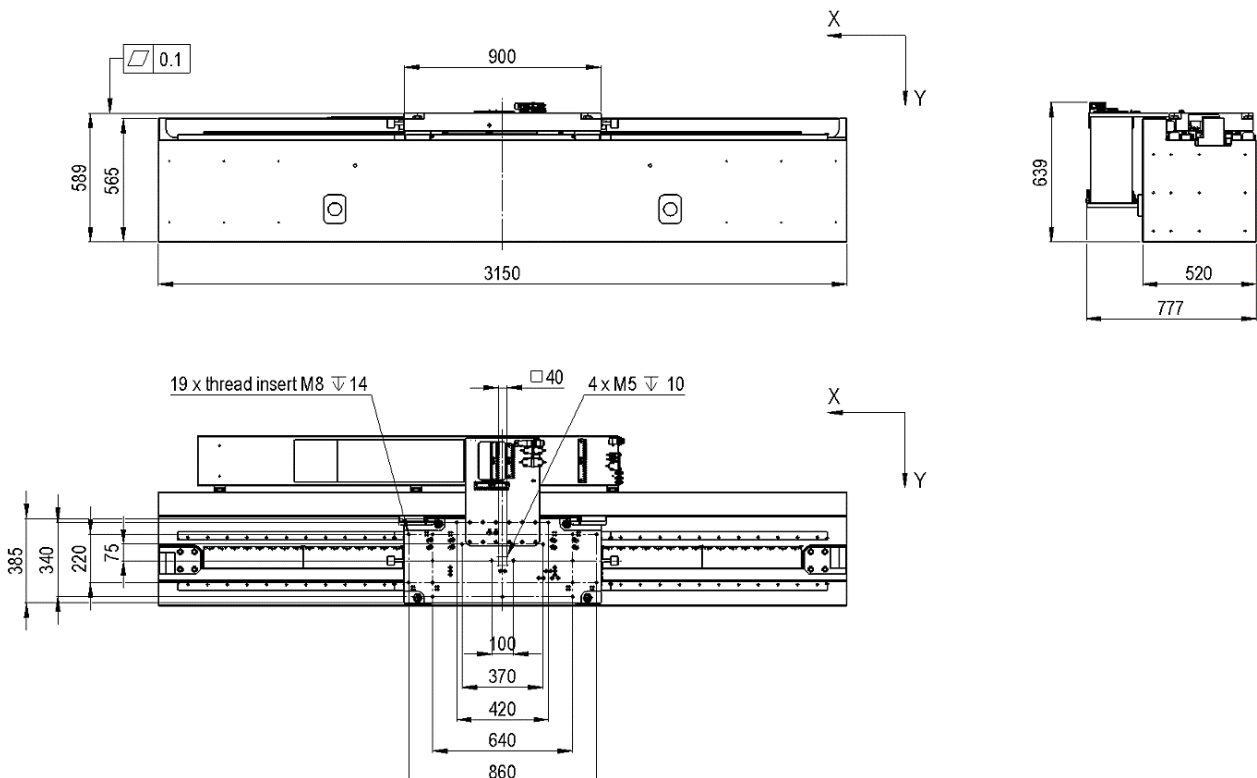

Specifications

Type	Unit	Value
Stroke	mm	2,000
Position Accuracy uncompensated (XTX)	µm	< 15
Repeatability (bidirectional) ¹⁾	µm	< 1
Position Stability ¹⁾	nm	50 - 100
Vertical/Horizontal Straightness (XTZ/XTY)	µm	7
Pitch (XRY)	µrad	25
Yaw (XRZ)	µrad	25
Max. Speed unloaded	m/s	2
Max. Acceleration unloaded	m/s ²	10
Mechanical Data		Value
Dimension LxWxH	mm	3,150 x 777 x 639
Max. Load ²⁾	kg	250
Load Capacity vertical (Z)	N	3,000
Load Capacity lateral (Y)	N	280
Moment of Tilt around X	Nm	25
Moment of Tilt around Y	Nm	20
Moment of Tilt around Z	Nm	70
Moving Mass (slide)	kg	85
Total Mass (incl. slide)	kg	2,600
Encoder		Value
Type		incremental, RSF
Sensor Signal		1Vpp
Drive		Value
Type		3-phase, synchronous, ironless
Max. Voltage ph-ph	V _{AC}	230 (300 V _{DC})
Continuous Force	N	384
Peak Force	N	1,960
Continuous Current	A _{rms}	3.6
Peak Current	A _{rms}	18.4
Interfaces and Environment		Value
Air Consumption	Sl/min	18
Supply Pressure	bar	5
MTBF	h	> 20,000
Limit Switch		included (5 V)
Clean Room Suitability		applicable
Drive Control		Value
Standard		Kollmorgen Servostar AKD / S300 / S700
High end		ACS controller, Triamec

1) depending on drive control

2) large mass moments of inertia must be taken into account

Subject to technical modifications and typographical errors.