

PhaseCam[®] 6010

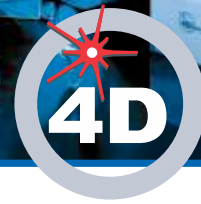

Dynamic Twyman-Green Interferometer

Instantaneous Acquisition

The PhaseCam[®] 6010 is a compact, dynamic laser interferometer operating at 632.8nm that incorporates a 4-MegaPixel camera with fully motorized control of all internal functions. With on-axis illumination and imaging, this Twyman-Green is ideal for optical path measurement of long radius meter scale concave mirrors, segments, telescope assemblies, collimators, and the alignment of complex optical assemblies and characterization of deformable mirrors.

The PhaseCam 6010 incorporates Dynamic Interferometry[®] technology, using a single camera, high-speed optical phase sensor to make wavefront measurements in less than 30 microseconds—over 5000 times faster than a temporal phase shifting interferometer. Because acquisition time is so short, the PhaseCam can be used under almost any conditions, without vibration isolation. This insensitivity to environmental factors makes the PhaseCam ideally suited for use on the production floor, in clean rooms and in environmental test chambers.

Compact and lightweight, the PhaseCam 6010 was designed with performance and remote measurement in mind. Moving the system to reconfigure a test set is simple and easy, and isolation equipment is not required. Fully motorized controls make it easy to operate the system in remote locations.

Complete Measurement System

The PhaseCam 6010 system includes the interferometer, 4Sight[™] Focus advanced wavefront analysis software, and complete computer system. Samples

with reflectivity from 1% to 100% can be measured with a simple adjustment. The diffraction-limited optical system maximizes sampling of the full aperture of the test part. Easy to use, the vibration insensitive PhaseCam 6010 ensures rapid and precise data acquisition.

Industry Leading Analysis

4Sight Focus wavefront acquisition and analysis software utilizes a user-friendly interface with unmatched simplicity, analysis features and graphical displays.

4Sight's 64-bit acquisition engine produces rapid analysis and display of single, averaged or burst measurements. Continuous data acquisition and real-time Zernike bar plots provide real-time visual feedback for simplifying optical system or beam train alignment.

The user-friendly interface makes data comparison, manipulation, masking, reference subtraction, filtering and terms removal simple to perform. Zernike, Seidel, geometric and diffraction analyses are standard. Comprehensive data sharing capabilities let you read, write, and save most file types, including Zemax, MatLab, Vision, MetroPro, HDF5 and CodeV.

FEATURES

- Turn-key vibration insensitive dynamic operation
- Superior instrument transfer function
- Fast data acquisition
- Continuously adjustable sample reflectivity compensation

APPLICATIONS

- Meter-class telescope optics
- Large imaging system alignment
- Vacuum and environmental chamber testing
- Production floor quality control
- Testing with computer generated holograms



PhaseCam 6010

PhaseCam® 6010

Specifications

Configuration	Model 6010 633 nm
Description	Vibration insensitive dynamic Twyman-Green interferometer
Acquisition Mode	Single camera, high-speed optical phase sensor
Optical Path	Fiber-coupled head and laser source module; 5 m fiber length
Laser Source	Stabilized HeNe source @ 632.8 nm
Typical Laser Power	<1.5 mW
Maximum Cavity Length	>100 m
Entrance Pupil Diameter	7 mm
Beam Diameter	7 mm FWHM
Divergers	Range of lenses from f/1 to f/32
Polarization	Circular
Focus Range	±12.5 mm, optical magnification dependent
Pupil Magnification	1X fixed, 10X digital zoom
Fringe Contrast	User adjustable for reflectivity from 1–100%
Camera	4 MPx, 12-bit standard
Data Array	User selectable full, half, quarter data arrays
Motorized Controls	Focus, reference beam block, aperture block, contrast adjustment
Computer System	High performance PC
Operating System	Windows® 10
System Software	4Sight™ Focus Analysis Software
	Instantaneous Phase Shifting data acquisition
	Reference generation, subtraction, data averaging, masking
	2D and 3D surface maps
	Zernike / Seidel / Slope / Geometric / Fourier Analysis
	Fiducial-aided data set mapping
	HDF5 data format standard, others supported
	Analysis of multiple sub-apertures
	Upgrades free during warranty period
Physical Envelope	Measurement Head: < 18.0 × 16.2 × 9.1 cm (7.1 × 6.4 × 3.6 in)
	Laser Source: 58.9 × 24.1 × 14.0 cm (23.2 × 9.5 × 5.5 in)
Weight	Measurement Head: < 4.5 kg (10.0 lbs)
	Laser Source: 10 kg (22 lbs)
Power consumption	< 750 Watts with computer
Temperature Range	Operational: 16–27° C (60–80° F), non-condensing
	Storage: -1–38° C (30–100° F), non-condensing
Divergers	Range of lenses from f/1 to f/32
System Performance	
Acquisition Rate	≥ 15 frames/sec live video
	≥ 15 frames/sec acquisition with post processing
Minimum Exposure	30 μsec
Sample Reflectivity	1–100%
RMS Repeatability	< 0.001 wave*
RMS Precision	< 0.002 wave**
Warranty	Two year, limited, on-site system installation and operator training

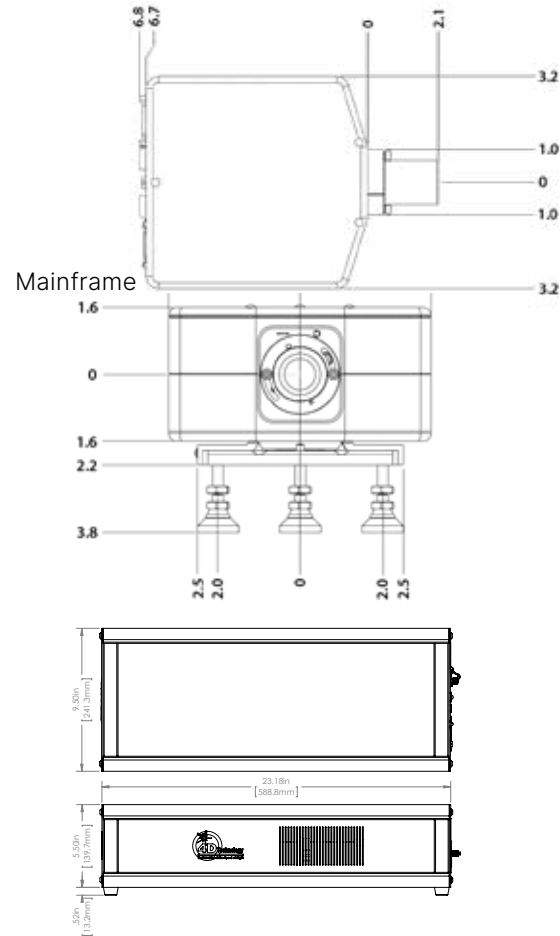

Source module

* One sigma for RMS of 10 data sets of calibration mirror, each data set being an average of 16 measurements.

**Average RMS of the pixel by pixel difference of 10 data sets between measured surface and the calibrated surface. Each data set is an average of 16 measurements. Calibrated surface is the average of all 160 measurements.

Patent 7,230,717. Other patents may apply.

PhaseCam and Dynamic Interferometry are registered trademarks of 4D Technology Corporation.

MetroPro IDL, MatLab, Opticode, Vision, HDF5, CodeV and Windows are registered trademarks of their respective owners.

All specifications subject to change without notice.

4D Technology

An Onto Innovation Subsidiary



2026.04.01 ■ ©4D Technology Corporation