

## GL OPTI LIGHT LED 127 CLC

The uniform, programmable multichannel LED light source available in one box featuring closed loop calibration (CLC).

The GL OPTI LIGHT LED 127 can be used as a calibration reference for cameras and other optical instruments, especially in industrial electronic testers, in addition to being a reference light source in laboratory applications and features closed-loop calibration using a high-accuracy photodiode. The product is also a color standard which can be programmed to any color output in a specific gamut.

### Features:

- Very high uniformity
- Near-perfect replication of light sources like D50, D65, D75, A, TL 84
- Free selection of light spectra out of color space bigger than sRGB\*
- Stable conditions thanks to a unique calibration method
- Much longer lifetime of LEDs thanks to the active thermal stability
- Closed loop calibration using a high-accuracy diode

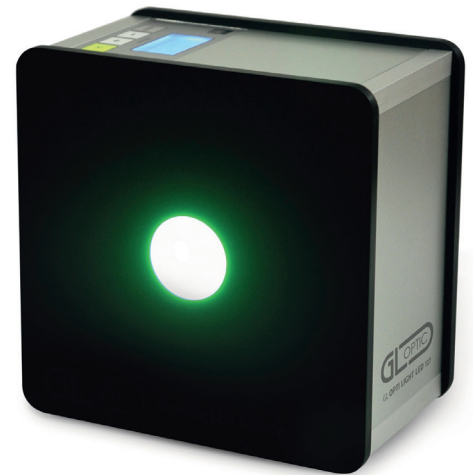

\*Available only with GL OPTI LIGHT CONTROL PROFESSIONAL software

PHOTOMETRY	
Application	Luminance and colometric standard
Luminance range	100 – 3000 cd/m <sup>2</sup>
Colometric stability	± 0.002
LED Color peaks	390; 450; 470; 520; 590; 633 nm (± 10 nm)
Color temperature	free selection (larger than sRGB)
Color coordinates	free selection
Colometric stability	guaranteed with active thermal stabilization
Luminance stability	± 1 %
LED Channels	adjustable
LED Controller	analog (no flicker)
Closed Loop Calibration (CLC)	featured
Autocalibration	Photodiode steered system
Flicker / ripple effect	None – stable light emission assured by CLC
Warm-up time	< 1 sec
TECHNICAL DATA	
Spectral range	385 – 750 nm
Dynamic range	1 – 300
Sphere inner diameter	127 mm
Aperture (exit port) diameter	47 mm
Uniformity	± 1 %
Linearity	0.05 %
Light source replication	D50, D65, D75, A, TL 84
Light source transition	automatic choice of smooth/fast transition 30 sec, 60 sec, 120 sec intervals
Lifetime	10000 hours
Power supply	DC 5V/5A

# Technical Sheet

## GL OPTI LIGHT LED 127 CLC

Operating temperature range	10 °C to 40 °C
Dimensions [H x W x D]	216 x 227 x 130 mm
Weight	approx. 4.5 kg
<b>INTERFACE</b>	
USB	USB 2.0 Socket B
Software Development	An SDK is available for Windows 32/64-bit
<b>DISPLAY</b>	
Display	LCD Monochrome display
<b>SOFTWARE</b>	
Software	GL OPTI LIGHT CONTROL PROFESSIONAL requires Windows
<b>ORDERING INFORMATION</b>	
Product number	GLL no. 173088
Case	Individual hard case
Case dimensions [W x H x D]	216 x 221 x 131 mm
Gross weight (device + case)	approx. 7 kg
<b>TECHNICAL DRAWING</b>	
Standard version	

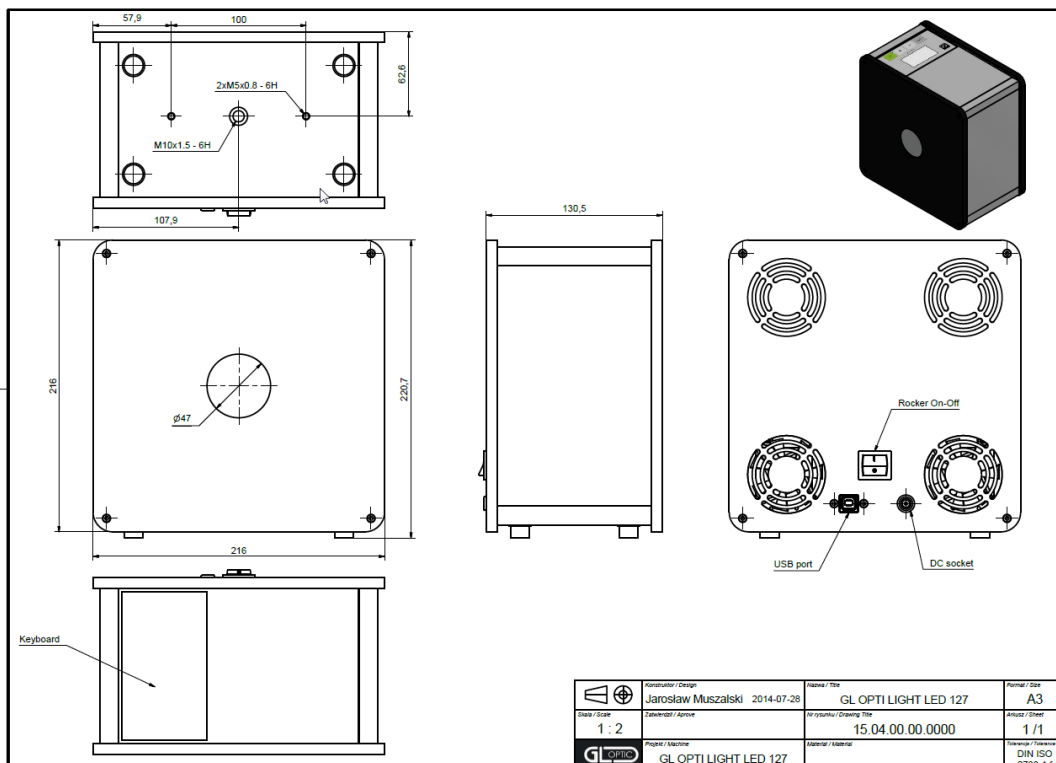

## GL OPTI LIGHT LED 127 CLC

### TECHNICAL DRAWING

OEM / Industrial applications

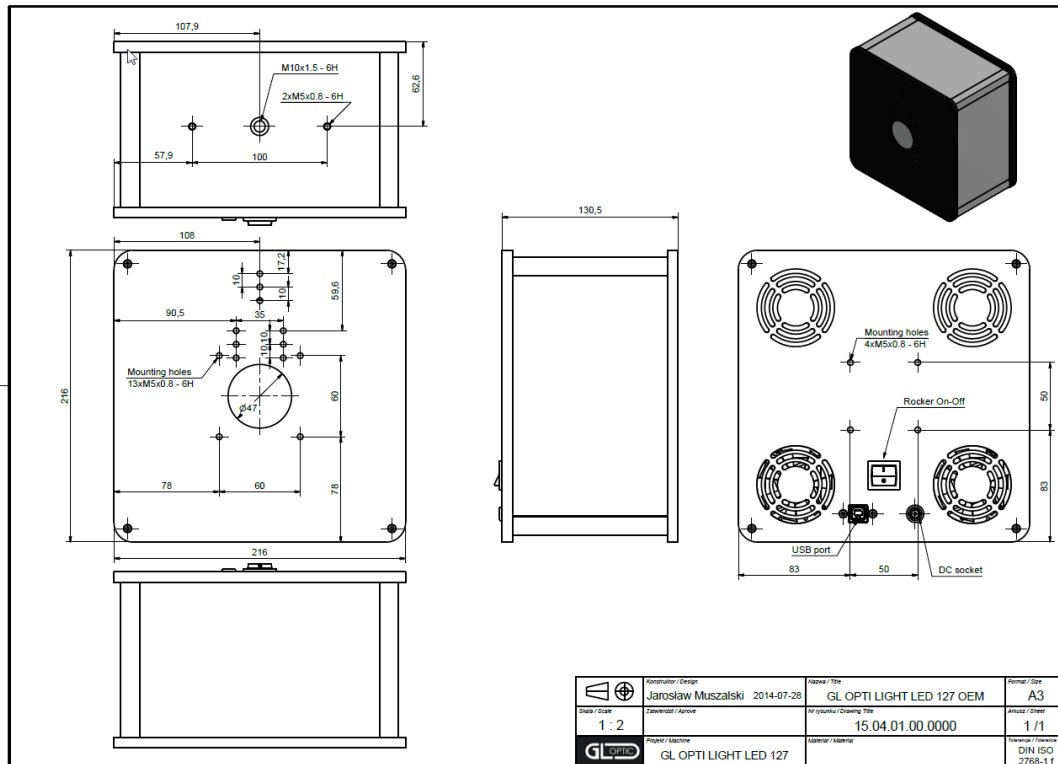

OEM/Industrial version features control capability via SDK

**Note:** Instrument, firmware and software specification are subject to change without prior notice. All information included in GL OPTIC datasheets and product information available in any form are carefully prepared and included information believed to be true. Please note that discrepancies may occur due to text and/or other errors or changes in the available technology. We advise to contact GL Optic before the use of the product to obtain the latest product specification.

GL Optic Lichtmesstechnik GmbH | Tobelwasenweg 24 | 73235 Weilheim/Teck | GERMANY | Tel.: +49 (0)7023 9504-20 | Fax: +49 (0)7023 9504-830 | office@gloptic.com | www.gloptic.com  
 Geschäftsführer: Michael Gall | Sitz der Gesellschaft: Weilheim/Teck | Amtsgericht Stuttgart HRB746271 | USt-IdNr.: DE 292228248 | Steuer-Nr.: 69068/56239