

# **LG-1.1**

## **Rotating Luminaire Goniophotometer**



## Part 1. LG-1.1 Budget Goniophotometers

The LG-1.1 is a midrange version of the LG-1 series of rotating luminaire goniophotometers. It is a compact goniophotometers for luminaire manufacturers or institutions who do not have the space, budget or need for a large, swinging mirror-type goniophotometer. It comprises a floor-standing goniometer, a photometer and a software interface.



**Figure 1: The LG-1.1 Goniometer**

## Theory of Operation

The sample is mounted on the goniometer and rotated around a pivot point through two axes of rotation. This presents the different orientations of the test item towards a detector, mounted at a distance across the room. Through this way the luminous intensity distribution of the test item is measured, and from this distribution other data such as luminous flux and beam width can be determined.

Windows-based software running on a PC coordinates the motion and the measurement, stores the data and produces professional reports.

This is a rotating luminaire goniophotometer and therefore the burning position of the lamp will change throughout the course of the test. It is therefore not ideal for measuring gravity-dependant light sources such as discharge lamps like HID and fluorescent lamps. However it is perfect for measuring sources such as LEDs.

## Goniometer

The goniometer is manufactured from aluminium and steel and is lightweight but robust. Once positioned and aligned it is fixed directly to the floor. An adjustable counterweight is used in the horizontal rotating section.

The vertical axis can rotate through 180 degrees (e.g. rotating in elevation angles from 0 to 180 degrees) and the horizontal axis can rotate continuously through 360 degrees (e.g. rotating in C-planes from 0 to 360 degrees). Both axes have better than 0.1-degree angular accuracy.

The intersection of the horizontal and vertical axes is called the “pivot point” of the goniometer.

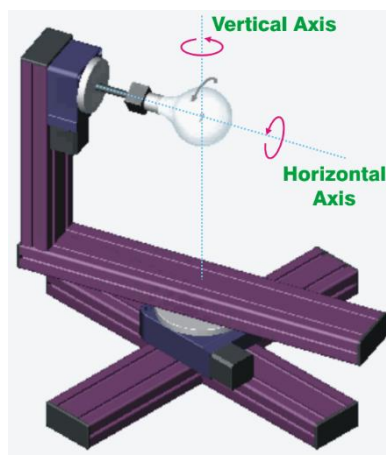

**Figure 2: Schematic Diagram of the LG-1.1 Rotation Axes**

The pivot point is approximately 1.25 metres above the floor level.

## Test Items

The **LG-1.1** goniometer can accept test items up to:

- 1300 mm in diameter, i.e. the gap between the pivot point and the lower arm of the goniometer is around 650 mm (see Figure 3);
- 400 mm in depth, i.e. the gap between the pivot point and the front face of the luminaire rotation table is more than 400 mm (see Figure 3); and
- 10 kg mass, assuming that the mass is evenly distributed and the luminaire is reasonably balanced.

These specifications cater for practically all types of lamps, individual LEDs or LED clusters and a variety of small to medium sized luminaires. The key dimensions are shown in the diagram below. In the picture on the right, the ruler shown is a 1 metre steel rule, which provides a reference for dimensions.

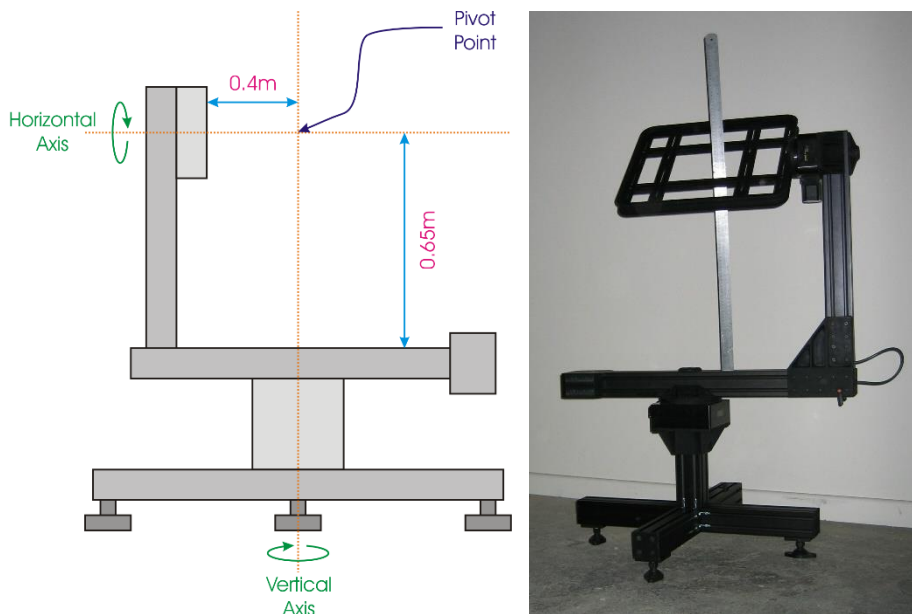

**Figure 3: LG-1.1 Dimensions**

Also shown in the picture above attached to the goniometer is a bracket, which is an adapter for testing floodlights in the Type B/ $\beta$  geometry.

Please note that these dimensions and loading specifications are customisable – please contact us for more information and pricing.

## Test Item Mounting

When testing, the photometric reference point of the test item being measured is positioned at the pivot point of the goniometer. The vertical section on which the test item is mounted may be moved back and forth along the horizontal section to accommodate test items of different sizes.

At the top of the vertical section is a rotary stage, which has a table containing various drilled and tapped holes for attaching mounting brackets.

## Photometric Measurement System

The measurement system (photometer) consists of a photocell, photocurrent preamplifier and analogue-to-digital converter. The photocell is thermostatically controlled at 35 °C and has an 8 mm receptive area and a responsivity of around 14 nA/lx. The photocell has a V (lambda) response with  $f_1' < 1.50\%$  (Class L), which is consistent with CIE and ECE recommendations for photocells for measurement of automotive devices and signals, and is therefore suitable for LEDs and coloured signals.

The photocell is fed into a multi-ranging photocurrent preamplifier, with built-in analogue-to-digital conversion, that is controlled by the PC. Digital or software triggering from the motor controller to the data acquisition card means that fast sampling of test scans can be achieved. The amplifier has variable integration time so that it can measure all types of sources including DC and also pulse-width modulated (PWM) light sources.

The photometer has an operating range from  $10^{-5}$  lx up to  $5 \times 10^4$  lx. This corresponds to around 0.0001 cd at a test distance of 3.162 metres. An ISO-17025 certified calibration certificate with traceability is provided with the system.



**Figure 4: Photocell and Amplifier**

### *Baffle Tube*

The photocell will be mounted in a baffle tube to block out any unwanted stray light from the walls, floor and ceiling. There are internal apertures inside the tube that prohibit reflections off the internal surface of the tube. Each baffle tube is custom-made, based on the client's preferred test distance and maximum test item size.

## Correction Measurements

The LG-1.1 is a rotating luminaire goniophotometer. The test item is aimed towards the photocell and rotated; therefore it is not mounted in its designed burning position and does not maintain a constant attitude during the test. This can affect the measurement of lamps whose light output changes when they are tilted to different angles, such as most types of discharge lamps.

Furthermore, for LED luminaires, the different mounting position (and therefore different air flow characteristics) may cause the luminaire to settle at a different temperature, which can affect the luminous output.

To correct for these effects we offer a Lamp/Luminaire Attitude Device (LLAD) – see optional extras.

## Software

The software that comes with the system is in two parts: control software to operate the equipment and report generation software to produce printed output. The big advantage of dividing the software into these two categories is that the report generation software can be installed onto other PCs so that reports can be produced while other measurements are being performed.

The control software that comes with the LG-1.1 is capable of performing measurements of luminous flux and also luminous intensity distribution.

When the software initialises, it checks all devices attached to the system to check that they are working properly. In the event of a failure or misbehaviour of one or more of the devices, an error message should be shown indicating which device is not functioning correctly and the most probable cause of the problem.

The control software has the flexibility to give the operator all of the control that he needs, and is not restrictive and rigid. Features include:

- Ability to specify test angles and angular increments;
- Ability to take measurements “on the fly” without stopping;
- Bare lamp luminous flux measurement or luminous intensity distribution measurement or both;
- Facility for monitoring the stability of test items;
- Joystick control for arbitrary rotations of goniometer axes;
  - Ability to select from a range of coordinate systems, i.e.
- Type C/ $\gamma$  for luminaires;
- Type B/ $\beta$  for floodlights;
- Type A/ $\alpha$  for signals and automotive test items;
  - Ability to set multiple calibrations, which are then selected according to lamp type (required for highest accuracy measurement);
  - Stray light subtraction, by measuring a single stray light value and then subtracting this from all measured data.

Some screen captures of the control software are shown below and on the following pages.

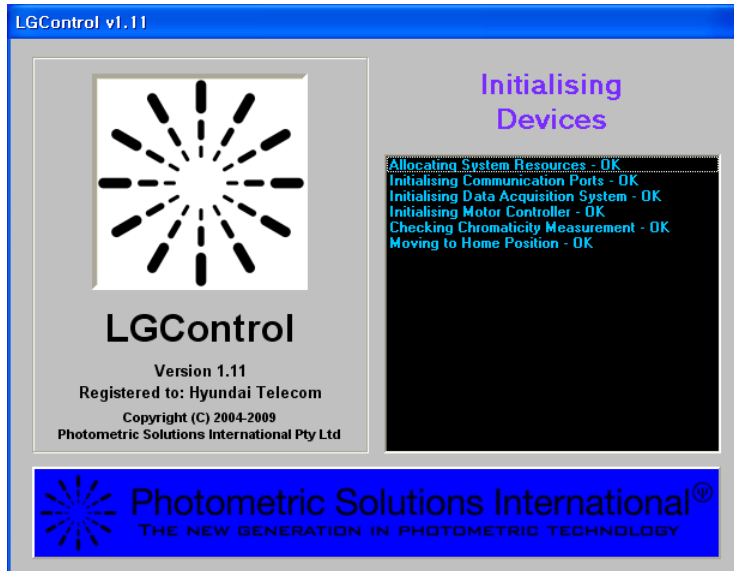

**Figure 5: Initialising Devices**

The software checks the devices attached to the system as it initialises.

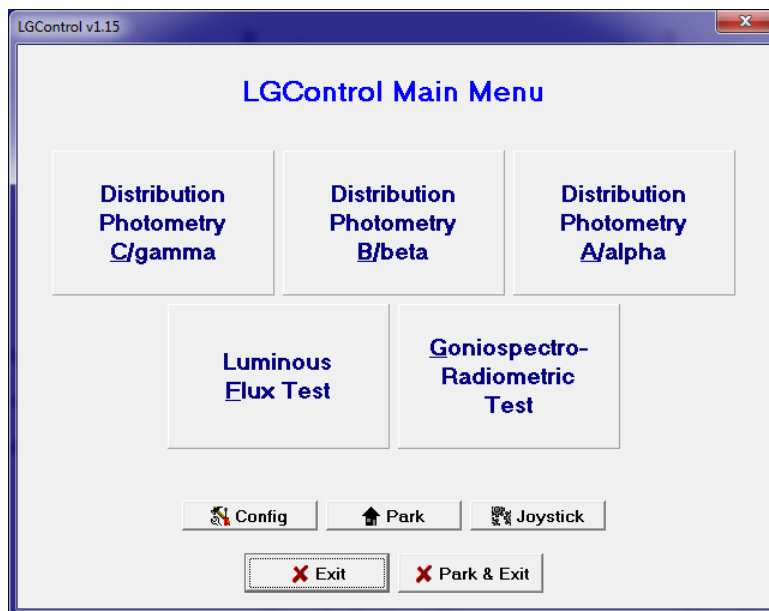

**Figure 6: Main Menu**

The software options in the main menu depend on the software configurations required and installed options.

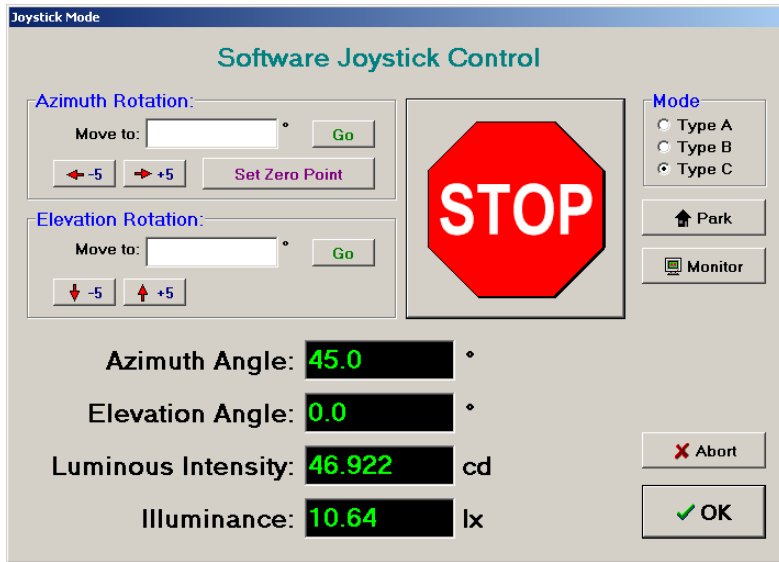

Figure 7: Joystick Control for Arbitrary Control of the Goniometer

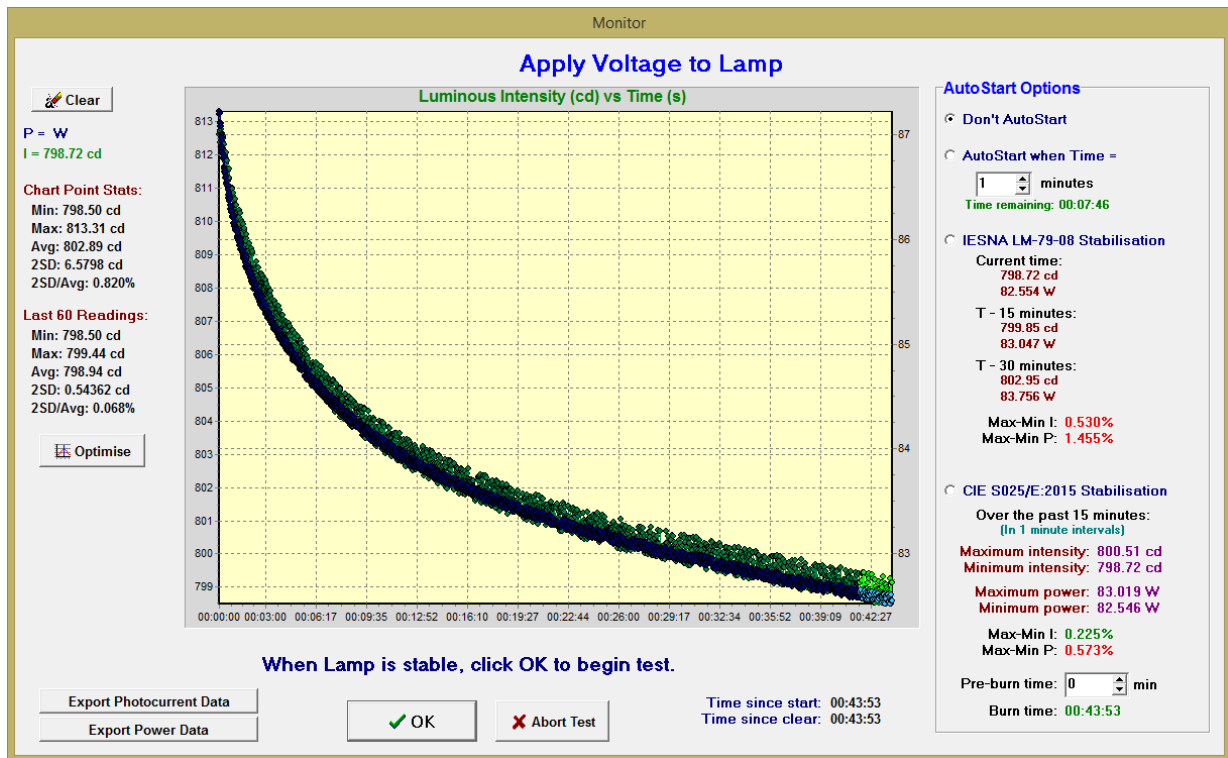
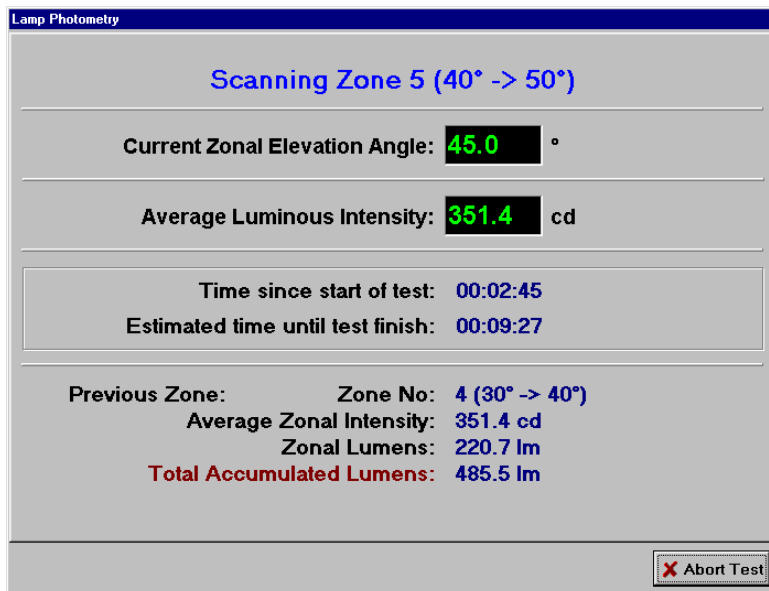
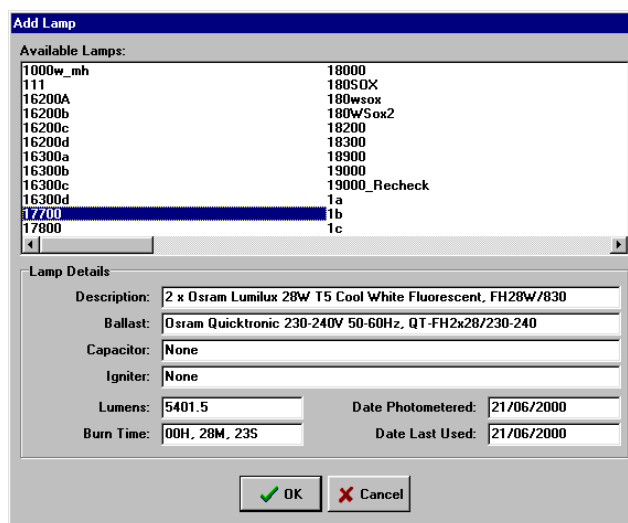

Figure 8: Photocell Monitor Window for Determining Test Item Stabilisation





**Figure 9: Bare Lamp or LED Luminous Flux Test**



**Figure 10: Standard Lamp Library for Relative Photometry**

The report generation software is also flexible. The user can select which pages are to be included in a report so that the report may be customised according to each client's needs. Fixed report generators that have a standard format for each type of test item are too restrictive.

Features of our report generation software include:

- Ability to customise the contact details and logo that appear on the printed pages;
- Test details with uncertainties of measurement;
- Polar curves and H-V plots – with ability to zoom in on lowest 10% regions to study spill-light;
- IsoCandela diagrams – Azimuthal projection format and H-V format;
- IsoLux diagrams – basic types only are needed here as there are many types of professional lighting-layout software available;
- 3D Web format for both the IsoLux and IsoCandela diagrams;
- Luminous flux summary table;
- Zonal flux diagram;
- Ability to display a digital image of the test item in the report for easy identification;

The IsoLux, IsoCandela and 3D Web format diagrams have options for line contour or shading formats, and the user can specify the values of the contours.

**Further information is in our other quote for our PhotometricSuite software. Please note that one licence of this software is provided free of charge with the goniophotometer system.**

## PC

The client is to provide a PC based on PSI's recommendations.

## Installation Requirements

The building arrangements are the responsibility of the client. This includes:

- Laboratory construction;
- Painting of room surfaces, where appropriate, a matt black colour;
- Construction of stray light baffles and curtains, where appropriate;
- Dust-proofing and air conditioning.

The room, or the space within the room which is dedicated to the LG-1.1 system, should be at least 4m wide and 2m longer than the test distance. The test distance should be at least 5 times longer than the largest dimension of the test item being measured, and preferably 15 times longer (see CIE 121-1996 "The Photometry and Goniophotometry of Luminaires"). For example, to measure test items up to 1.0 metres in diameter we recommend a test distance of at least 15 metres, while to measure test items up to 1.6 metres in diameter the test distance should be 24 metres.

Stray light baffles such as wooden panels or curtains should be placed on the walls, floor and ceiling. PSI staff can advise the client of the requirements for the baffles in advance or at the time of installation.

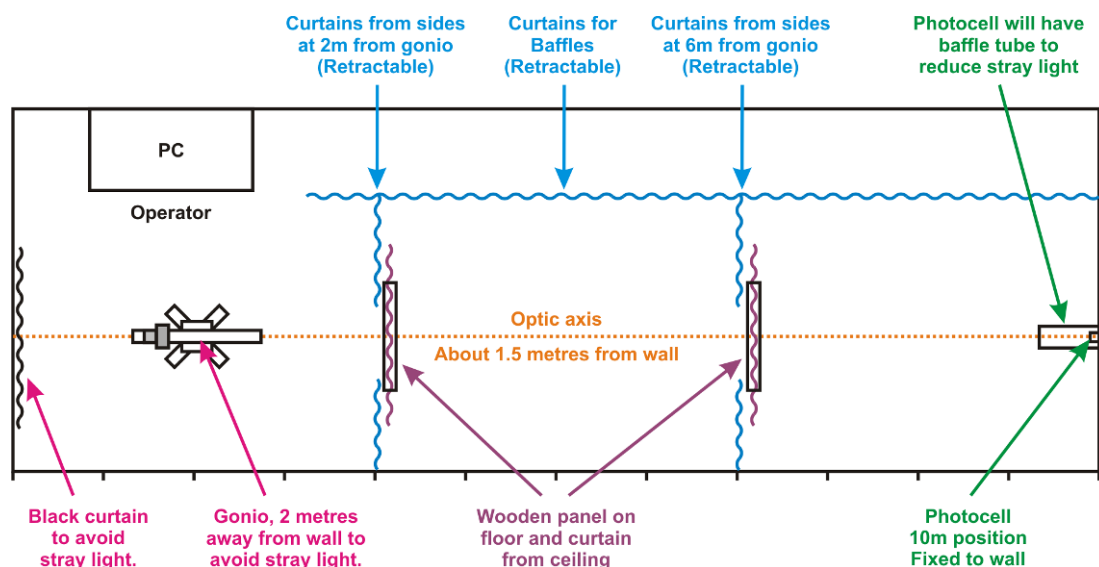

**Figure 11: Sample Layout for a room 12 x 4 metres**



**Figure 12: Curtains and wooden panels for baffling**

The entire room or area should be light-tight and dust-proof. The room needs to be maintained at 25 degrees Celsius and preferably around 50-70% humidity.

Mains supply should be properly earthed, stabilised and filtered. The mains electrical supply for the entire system should be provided through an uninterruptible power supply (UPS) system, or at the very least through a voltage stabiliser, and should include an isolation transformer and line filter. PSI can advise the client regarding the best locations of power outlets.

PSI will professionally pack the equipment in solid wooden crates.

### *Shipping Terms*

FCA Melbourne

### *Documentation*

The equipment and software provided comes with a User Manual (in English) which details the procedures for measuring lamp luminous flux and luminous intensity distributions with the LG-1.1 system in easy to follow instructions. The manual also contains connection diagrams and troubleshooting guides to the various components of the system.

### *Installation and Training*

Installation and training are not included in the price but can be made by special arrangement.

### *Warranty*

PSI provides an unconditional warranty on all of the photometric equipment supplied for 12 months from the date of final acceptance, or according to the limitations of the warranty of the manufacturer of any individual component. During the warranty period, PSI will repair or replace any faulty equipment at no charge to the client. The client is responsible for fixing hardware failures in the PC

system, however PSI will actively assist the client in determining the nature of and resolving any such problem that may occur.

This warranty does not cover misuse, abuse or accidental damage to the equipment. In such a case all repairs and travel and accommodation expenses will be borne by the Client.

## Part 2. Optional Extras

### Lamp/Luminaire Attitude Device (LLAD)

The LG-1.1 are rotating luminaire goniophotometers. The test item is aimed towards the photocell and rotated; therefore it is not mounted in its designed burning position and does not maintain a constant attitude during the test. This can affect the measurement of lamps whose light output changes when they are tilted to different angles, such as most types of discharge lamps.

Furthermore, for LED luminaires, the different mounting position (and therefore different air flow characteristics) may cause the luminaire to settle at a different temperature, which can affect the luminous output.

To correct for these effects we use a Lamp/Luminaire Attitude Device (LLAD).

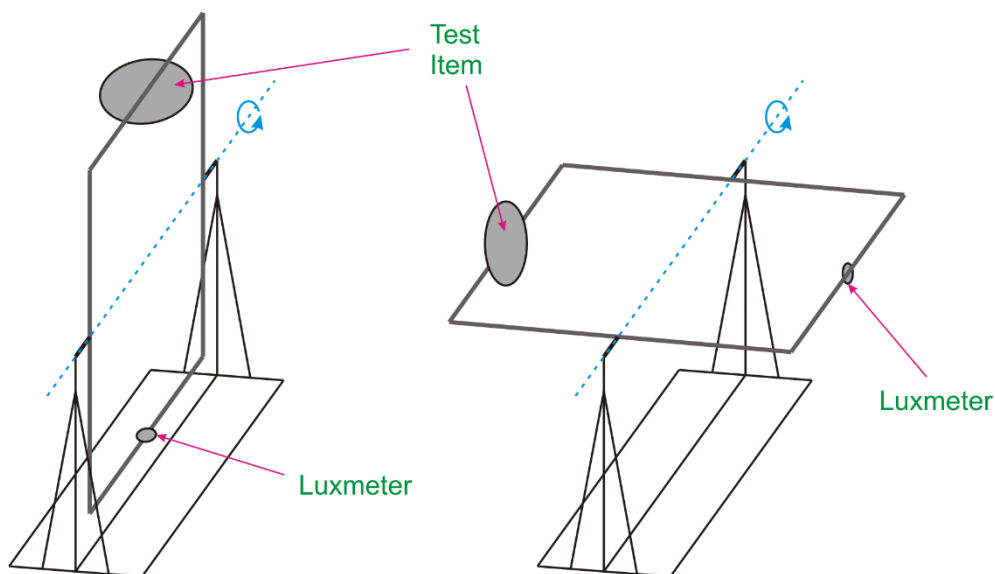

**Figure 13: Lamp/Luminaire Attitude Device (LLAD)**

The LLAD consists of a cradle with a frame that can be rotated about a horizontal axis. It has a mounting bracket onto which the test item can be attached and a luxmeter with a detector that is in a fixed position with respect to the mounting bracket. Thus the luxmeter's detector has the same view of the test item regardless of the angle to which the frame is rotated.

The test item is mounted on the LLAD and the frame rotated so that the test item is in its designed burning position, e.g. aiming directly downwards (see Figure 11, left). The test item is then switched on and allowed to fully stabilise. The luxmeter then takes a measurement.

The frame is then tilted in the cradle so that the detector is in the horizontal position (see Figure 11, right). This is now equivalent to the measurement condition when the test item is mounted on the goniophotometer. The test item is allowed to stabilise again and luxmeter then takes a second measurement.

The luxmeter has now taken two measurements: one with the test item in its designed burning position and one with the test item in the orientation that it will be mounted on the goniophotometer. These two measurements can be used to correct the measurements made on the goniophotometer to the performance of the luminaire in its designed burning position.

The scope of supply this optional extra is as follows:

- LLAD cradle and frame;
- Luxmeter with remote detector head;
- Software to perform the measurement and calculate the correction.

### *Photometer Calibration by NMIA*

The photometer comes standard with a calibration certificate from PSI's in-house ISO-17025 accredited laboratory. For some photometric laboratories, however, a higher accuracy (lower uncertainty) calibration may be preferable. This option provides for a calibration by Australia's National Measurement Institute.

Please note that this option increases the delivery time by approximately 4-6 weeks.

### *Power Analyser with Software Interface*

We will supply one Yokogawa WT310E power analyser to measure the electrical parameters of the devices that you are testing. The WT310E is a single phase power analyser with a basic accuracy for all input ranges is 0.1% rdg + 0.05% rng (50/60Hz) and DC 0.1% rdg + 0.2% rng.

This option includes a software interface where our control software will automatically read the voltage, current, power, power factor (other parameters optional) of the device at the start of the test, during the test and at the end of the test and save the average electrical parameters in the test results data file.

### *AC/DC Power Supply*

We offer the California Instruments Model 1501ix AC/DC power supply. This is capable of:

- 1500 VA AC power source, 0 – 300 V, 6.5 Arms in high range, 13 Arms in low range;
- Frequency output 16 Hz – 1000 Hz;
- DC output 0 - 400 V 0 - 6.5 A 1000 W;
- Includes USB & GPIB interface plus powerful Windows control software to set up and control power supply remotely;
- Capable of Transient Generation, Power Analyser Measurements & logging results, Arbitrary Waveform Generation, Generate Harmonic Distortion and also Waveform Acquisition for inrush current.
- Generate your own waveforms and play back through power supply.
- AC mode, DC mode plus AC+DC mode of operation.