

## PSH25 (SG) OEM

### 2-Axis Mirror Tilting System

#### Concept:

The PSH25 (SG) OEM is a new development in the mirror tilting systems PSH series offered by piezosystem jena. The series PSH serves fast and precise positioning of optical components. Mirrors or prisms can be positioned in the mrad range at up to several kilohertz.

#### Specials:

The PSH25 (SG) OEM is characterized by the positioning of optical components in two axes. A tilting range of up to  $\pm 20$  mrad (open loop)/  $\pm 16$  mrad (closed loop) is available. Another key feature is the easy exchange of different optical components.

The tilting system PSH25 (SG) OEM can be equipped with an integrated positioning sensor. Positions can be controlled ultra exactly and a previously established tilt range can be set. The positioning is highly repeatable with 13  $\mu$ rad accuracy.

Optics and optical components in various sizes can be mounted onto this tilting system.



image: PSH25 (SG) OEM

#### Product highlights:

- Sub- $\mu$ rad resolution
- Tilting range of up to  $\pm 20$  mrad (open loop) and  $\pm 16$  mrad (closed loop)
- Compact design
- Suitable for dynamical applications

#### Applications:

- Laser scanning
- Laser beam stabilization
- Image processing and stabilization
- Optical filters/ switches
- Scanning microscopy (SPM)

#### Options:

- Additional mirror retainer (part no. K-025-99)
- Special calibration for special optics
- Vacuum application

## PSH25 (SG) OEM

### Technical Data

	Unit	PSH25 OEM		PSH25 SG OEM	
<b>Part no.</b>		<b>K-125-00</b>		<b>K-125-01 (D/E)</b>	
<b>Axes</b>	-	<b>Θx</b>	<b>Θy</b>	<b>Θx</b>	<b>Θy</b>
<b>Tilting range open loop</b>	mrad	±20		±20	
<b>Tilting range closed loop</b>	mrad	-		±16	
<b>Resolution open loop*</b>	μrad	0.2			
<b>Resolution closed loop</b>	μrad	-		0,3	
<b>Repeatability</b>	μrad/%	-		13/0.05	
<b>Max. non linearity</b>	μrad/%	-		0.4/0.002	
<b>Electrical capacitance</b>	μF	1.64			
<b>Sensor</b>	-	-		strain gauge	
<b>Voltage range</b>	V	-20 ... +130			
<b>Resonant frequency</b>					
13 g mm <sup>2</sup> (mass moment of inertia, 0.5" mirror)	Hz	1400			
80 g mm <sup>2</sup> (mass moment of inertia, 1" mirror)		500			
<b>Dimensions (l x w x h)</b>	mm	60 x 60 x 40.5 (2.4" x 2.4" x 1.6")			
<b>Temperature range</b>	°C	-20 to +80 (-4°F to 176°F)			
<b>Material</b>	-	aluminium			
<b>Weight</b>	g	350 (12.3 oz)			

\* Resolution is limited only by the noise of control signal.

# PSH25 (SG) OEM

## Drawings

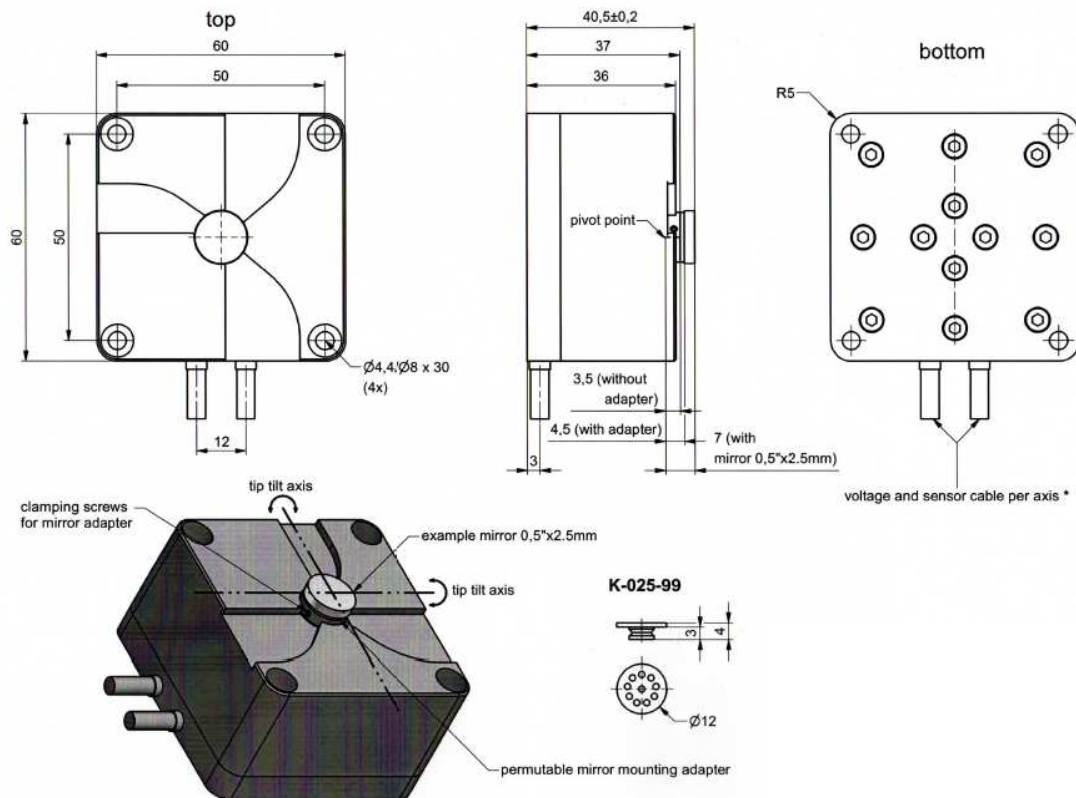

Specifications subject to change without notice!

Tel: +49 (3641) 66880 • Fax: +49 (3641) 668866  
[info@piezojena.com](mailto:info@piezojena.com) • [www.piezosystem.com](http://www.piezosystem.com)

